

TRAVELLER 3 SPINNING WHEEL

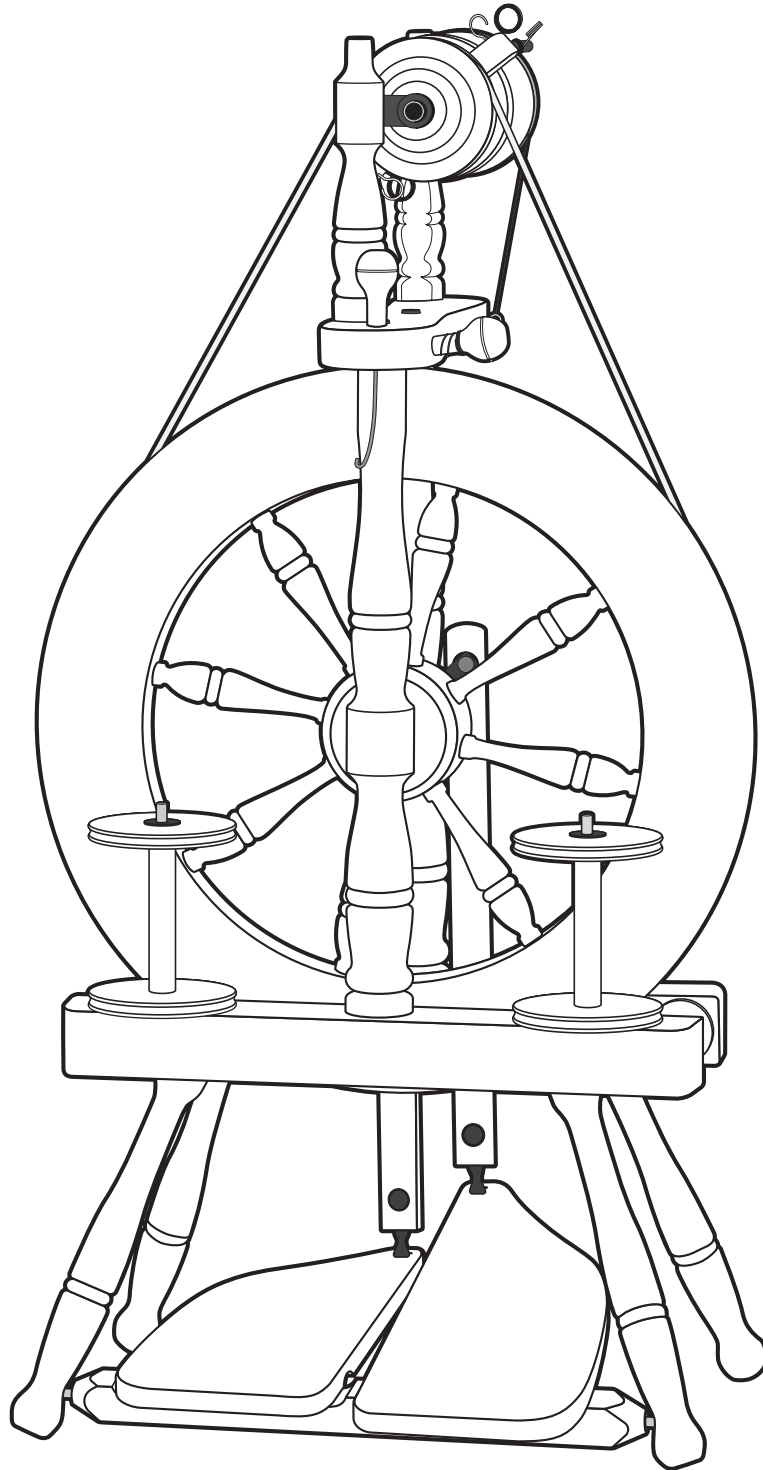

TSW3080623V1

ASSEMBLY INSTRUCTIONS FOR THE ASHFORD TRAVELLER 3 SPINNING WHEEL

Before commencing, please read these instructions completely, identify the parts and note the assembly sequence.

Remove any sharp corners or edges and smooth the surface of the wood with the sand paper provided. We recommend that the wood surfaces be waxed or sealed before assembly. This protects the kiln dried wood from the climatic changes and prevents it getting dirty or stained. The Beech timber has a

lovely variety of colour and grain. For a silky smooth matt finish, use the Ashford Finishing Wax Polish to enhance the natural colours and character of this timber.

If you are assembling your spinning wheel on a table, we recommend you protect the surface with a towel, blanket or cardboard. Ashford spinning wheels are also available factory finished in clear lacquer.

Tools Required

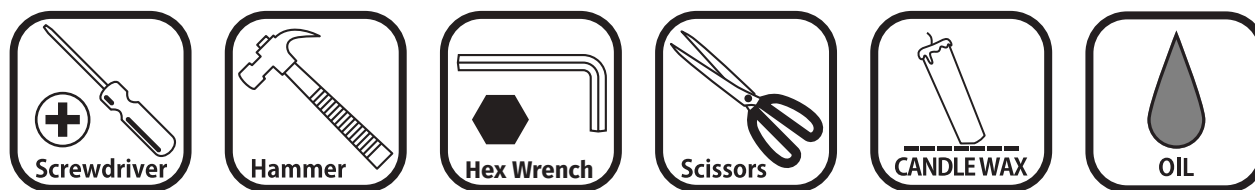

**Supplied*

Hints

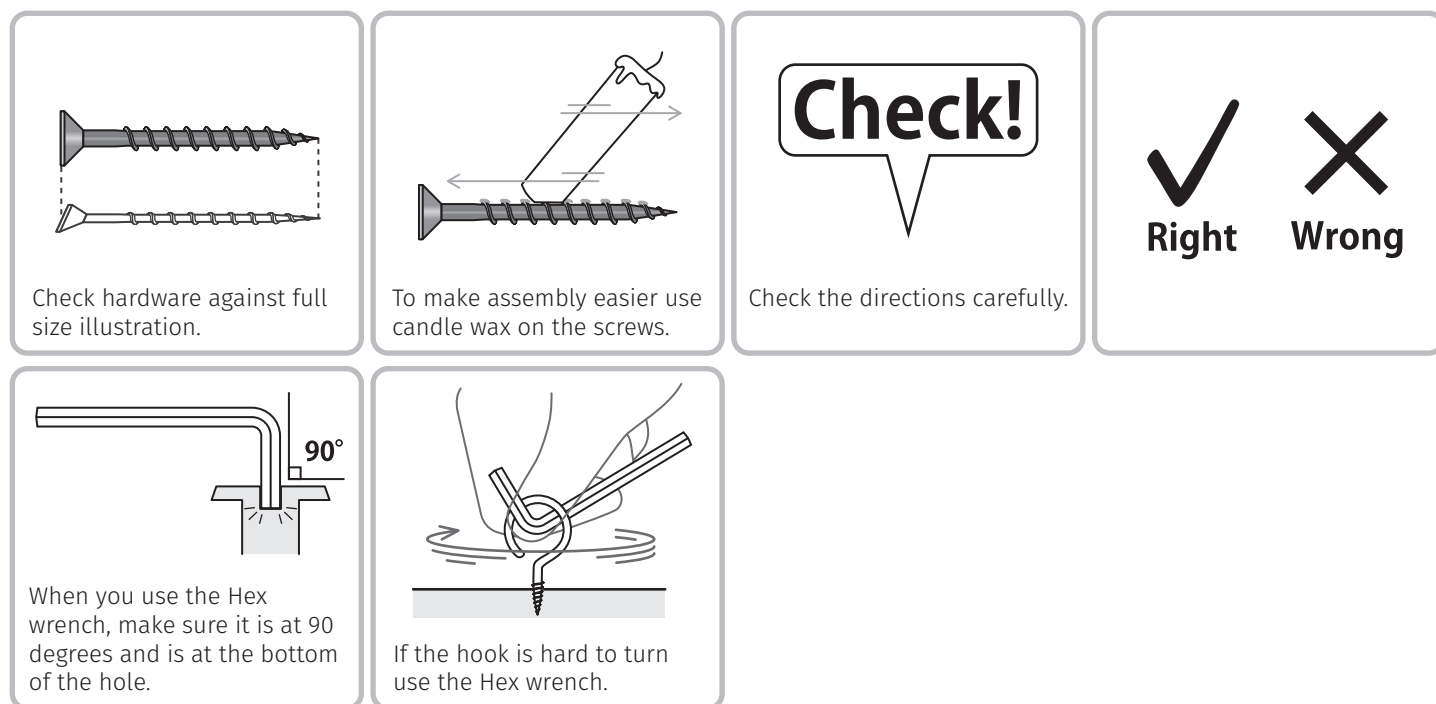

More Information



How-to videos on You Tube

Watch our how-to videos on You Tube.
@AshfordNZ



Facebook

Join us on facebook ashford.wheels.ooms

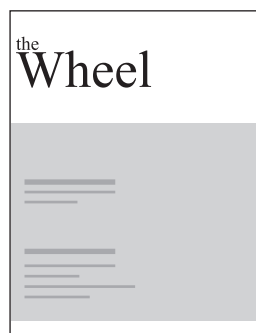

The Wheel Magazine

Ashford's annual fibrecraft magazine. Spinning, weaving, felting, dyeing and knitting projects, patterns and articles from around the world. To receive the glossy version delivered to you, subscribe at: www.ashford.co.nz/subscribe

Real Scale Hardware List

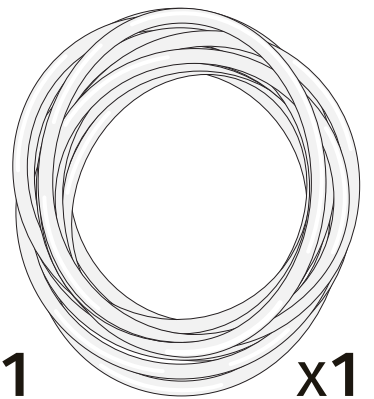
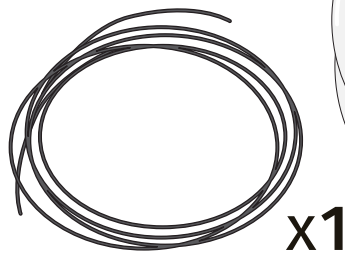
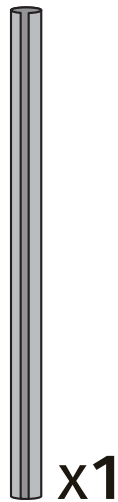
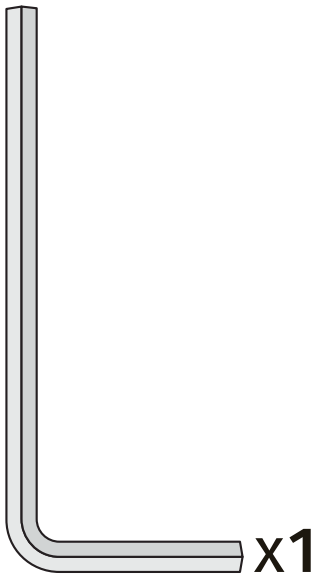
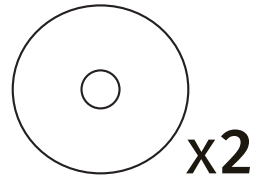
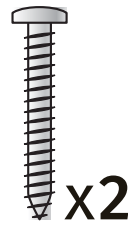
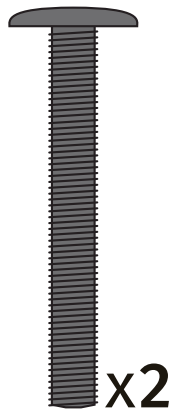
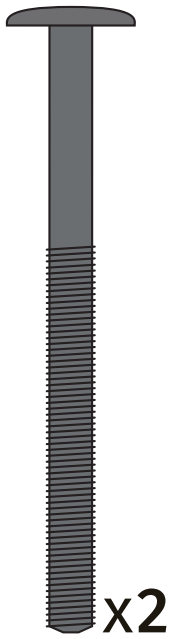
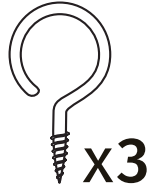
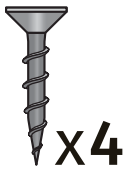

1 

Check the holes in the base for the lazy kate pins are to the front.

Wax the steel rods in the treadle rail and the ends of the legs.

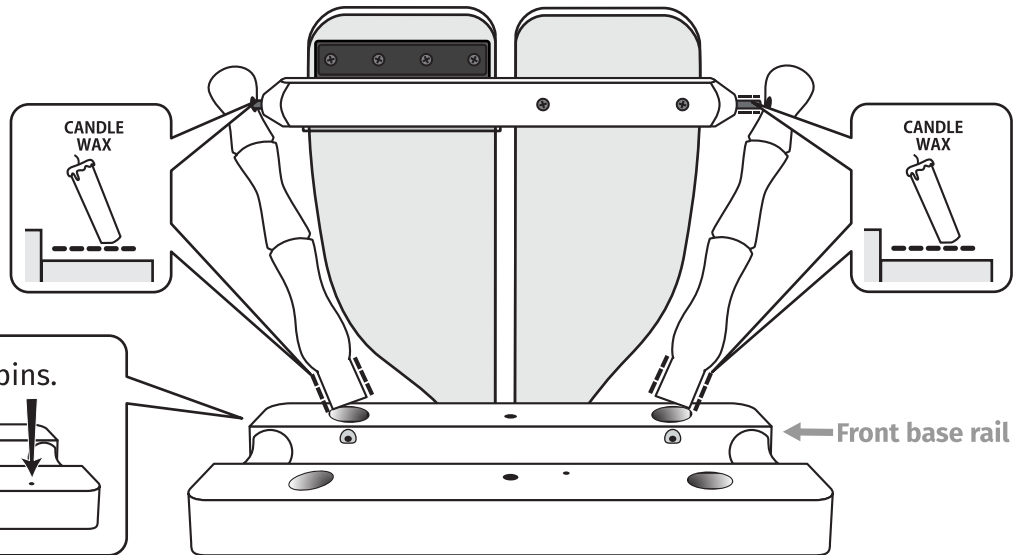

Check!

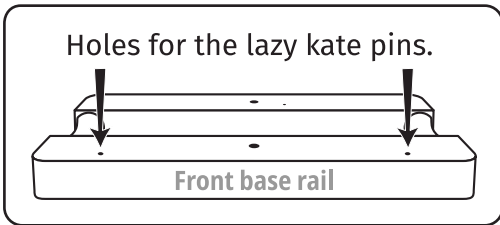

2 

Locate the treadle rail into the holes in the 2 front legs. Check the treadle rail rotates freely. Then tap these legs to the bottom of the holes in the front base rail.

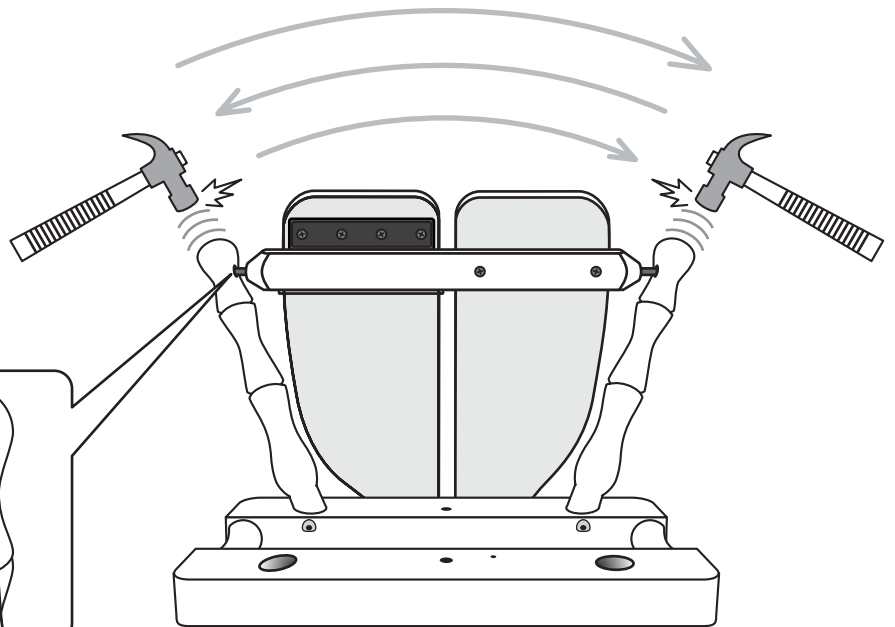

Check!

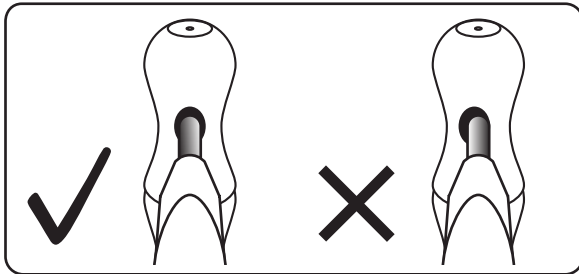

3  

Wax, then tap the 2 back legs to the bottom of the holes in the back base rail.

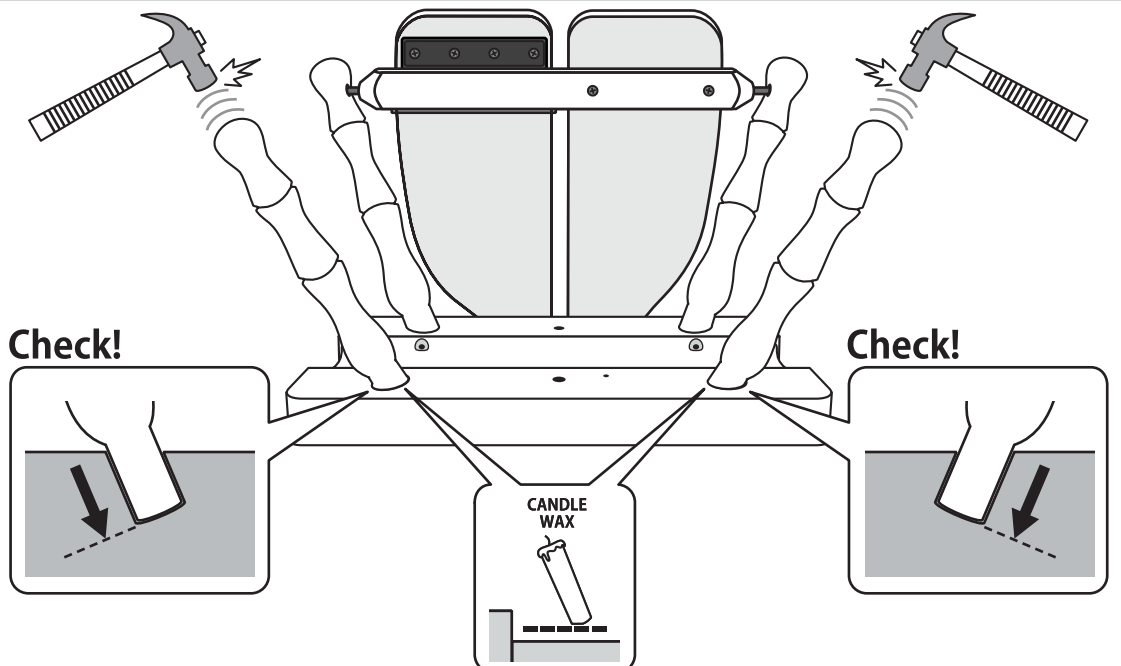

4



Secure the 4 legs with screws.

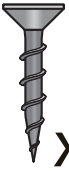
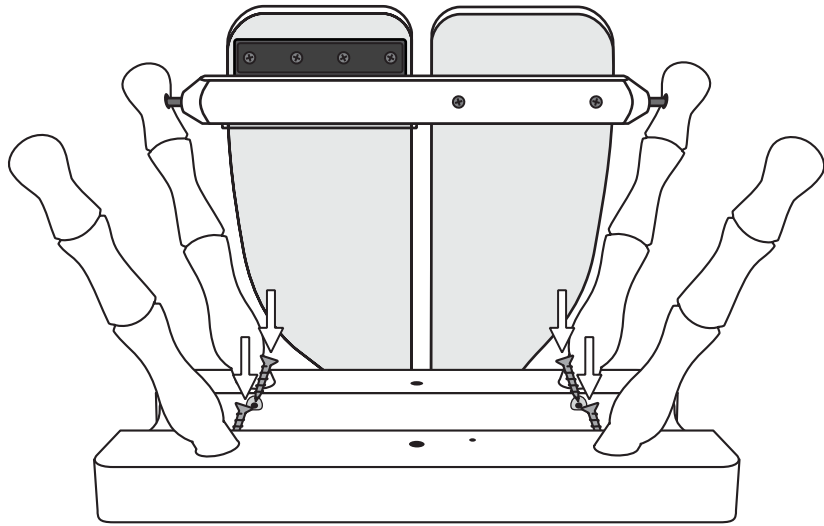

x4

5



Turn the base and legs over.
Secure the rear wheel support with bolt and barrel nut. This will be tightened later.

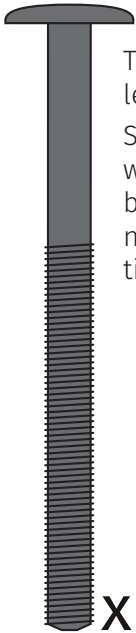

x1



x1

Check!

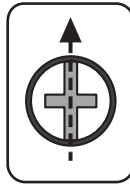

Check!

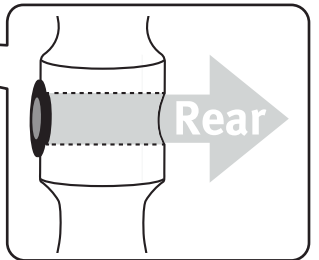

Note the hole in one wheel support is right through. This is the rear support.

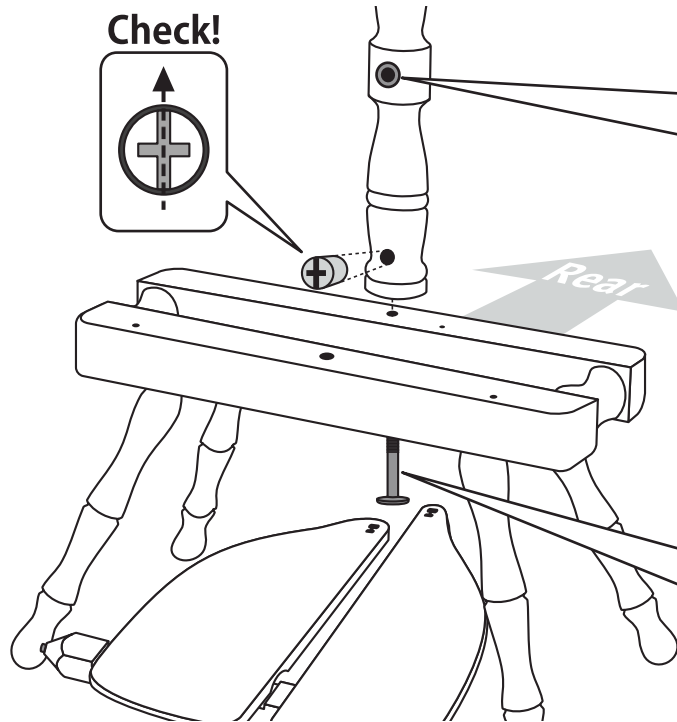

Check!

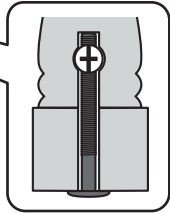

6



Secure the front wheel support with bolt and barrel nut. It will be tightened later.

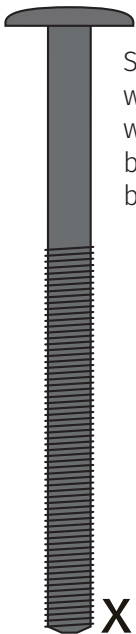

x1



x1

Check!

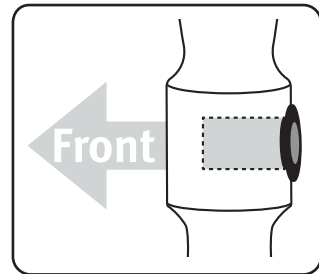

Check!

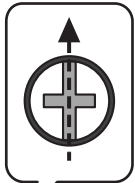

Check!

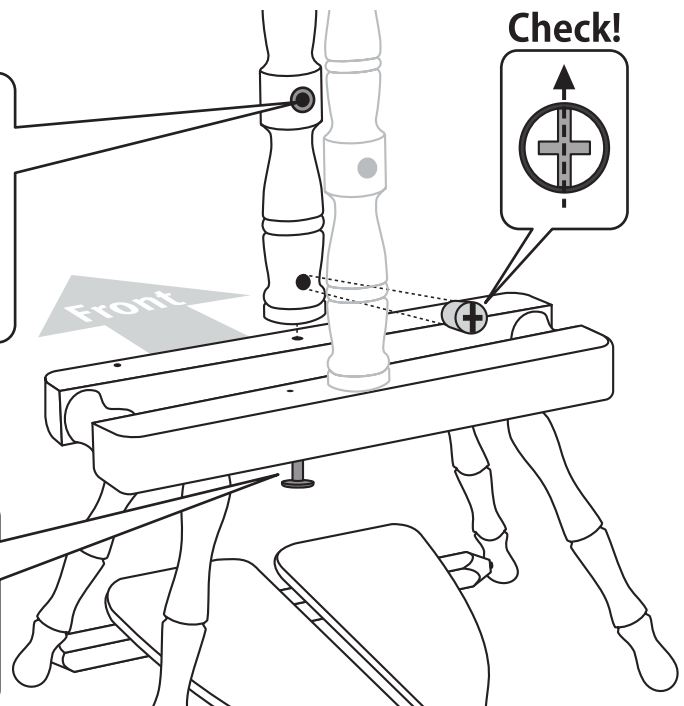
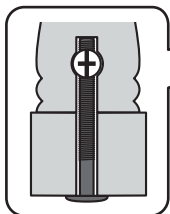



Assemble the flyer unit.
Check the shape of the nylon bearing on each maid upright, wax then insert into the correct hole.

Check!

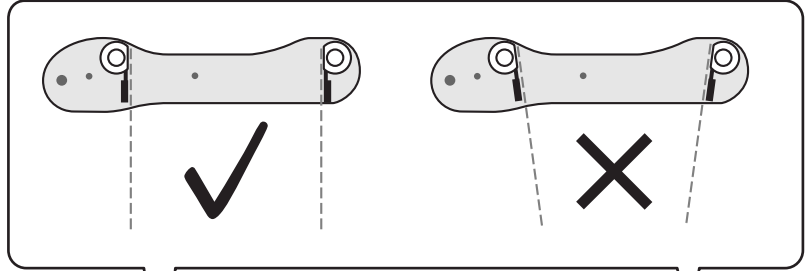

Check the angle of the nylon bearings and then secure the maid uprights with screws and washers. Do not overtighten. The maid uprights may be twisted to remove the bobbin.

Thread the screw eye into the front of the maiden bar and the screw hook into the back.

Check!

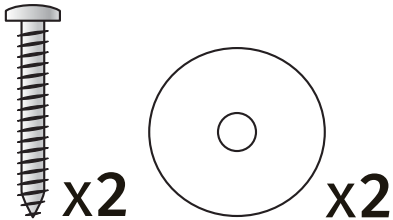
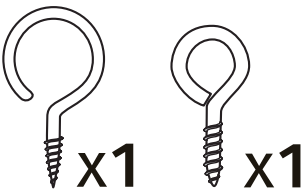
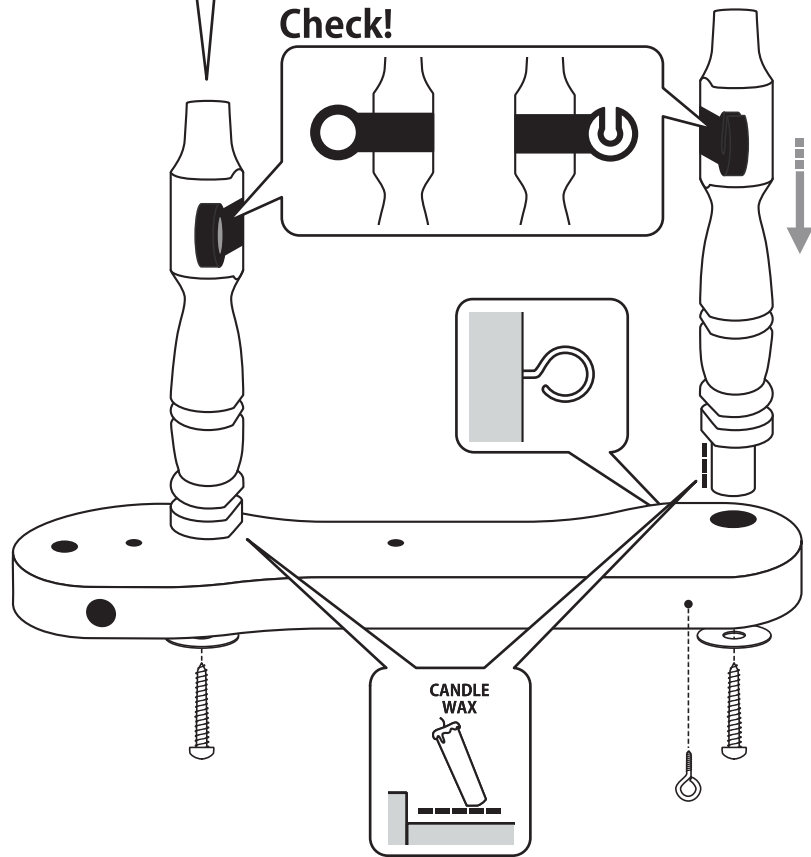

Locate the stretchy drive band between the wheel supports.

Check!

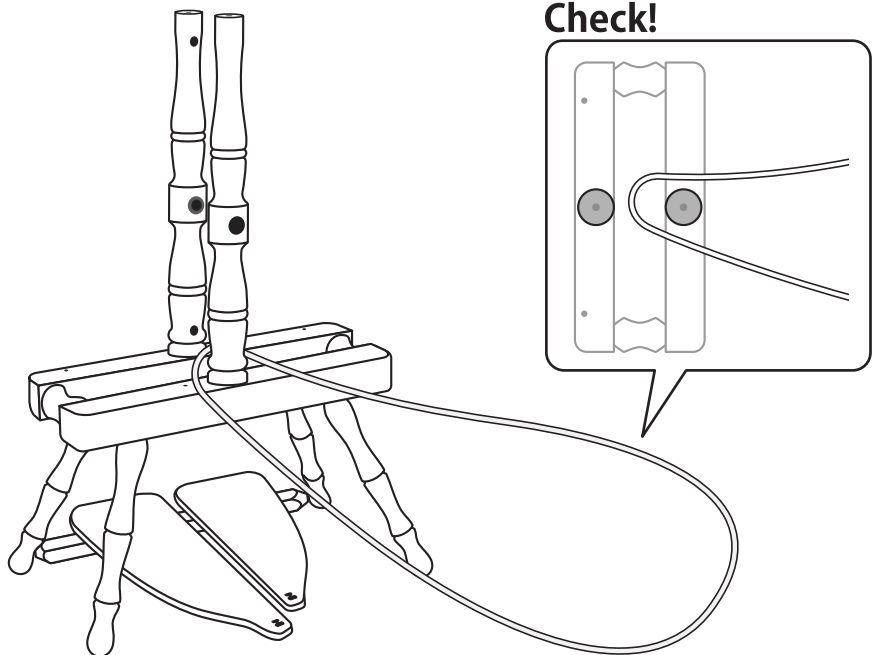
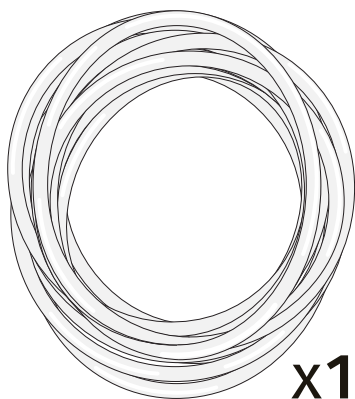

10

Locate the wheel with the groove for the hub pin to the rear, between the wheel supports and let it rest on the 2 base spacers.

11



Secure the maiden bar to the wheel supports with bolts and barrel nuts. They will be tightened later.

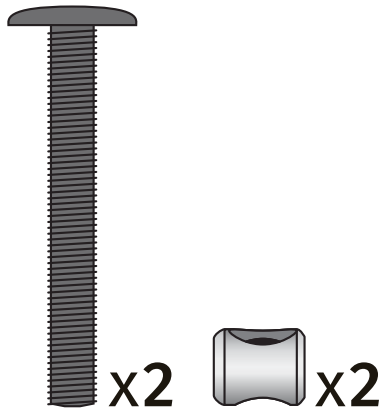

Check!

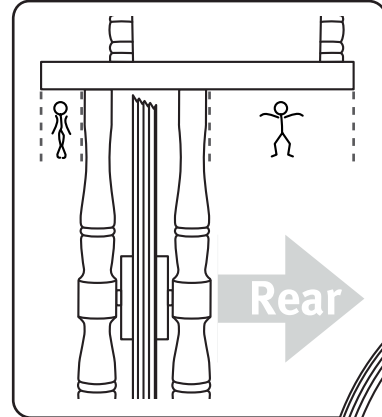

Rear

Check!

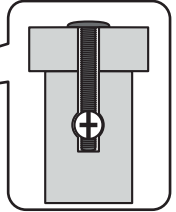

Check!

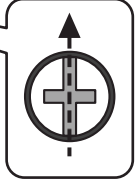

Check!

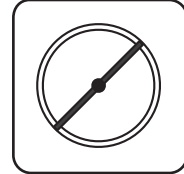

Base spacer

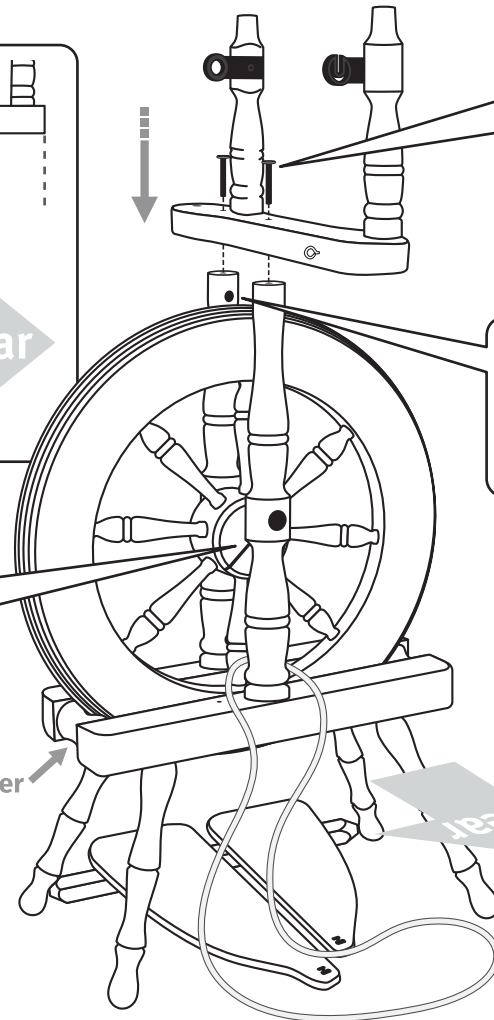

Rear

12



Lift the wheel into position and fully insert the crank. Check the wheel is parallel in the centre of the base and the wheel supports are tight against the hub. Then tighten the 4 bolts.

Check!

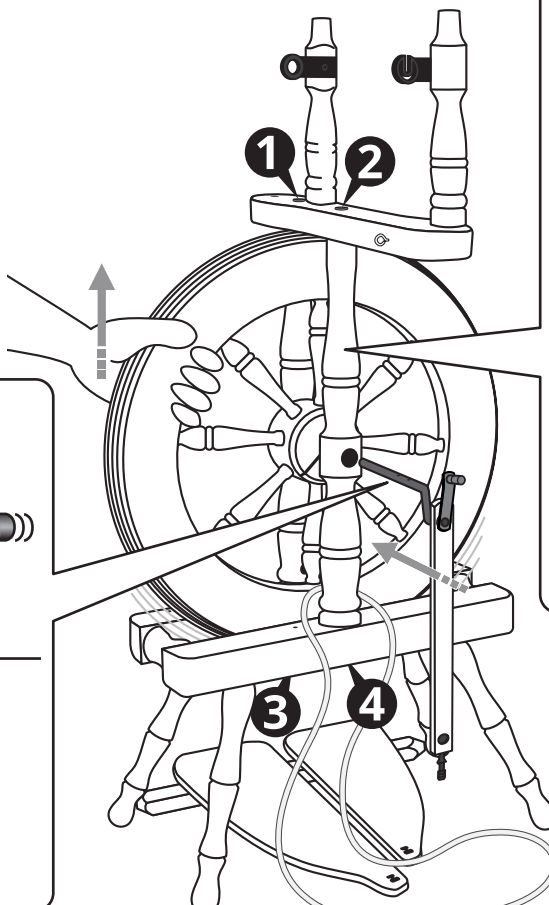
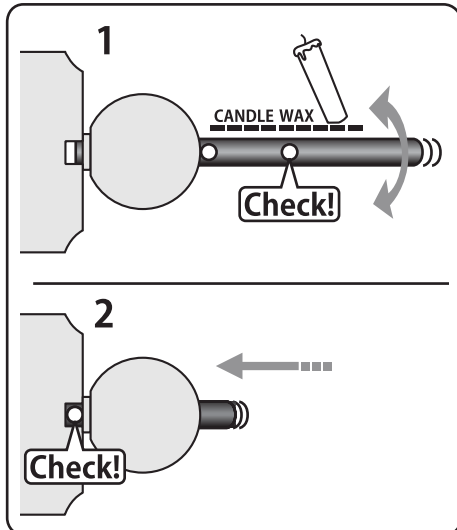
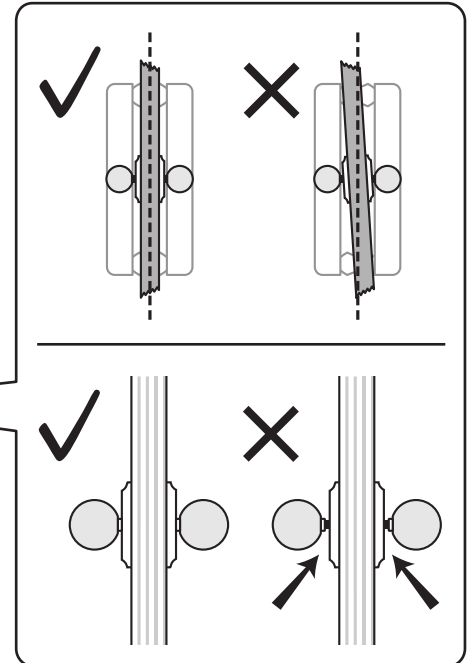

1 2 3 4

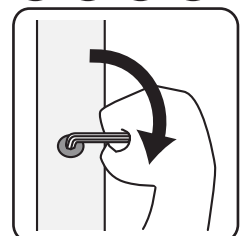

13



Align the groove in the hub with the hole in the crank.

Rotate the hub pin until it is a firm fit in the slot in the hub. Then tap the hub pin through the hub and crank.

Hint: Use a lazy kate pin as a punch to avoid damaging the hub.

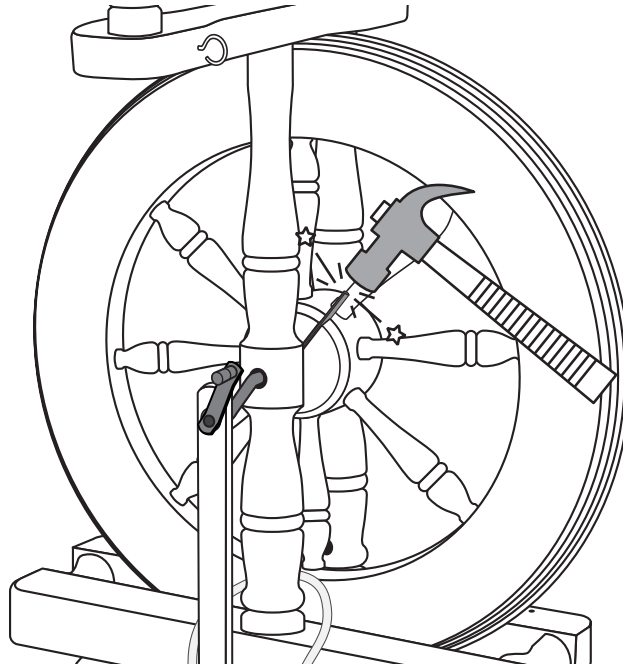

Check!

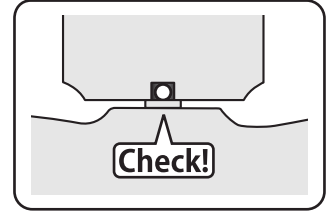

Check!

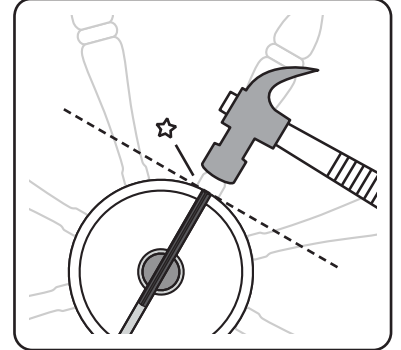

14



Slide the inner shell of the conrod universal joint onto the crank until it clicks into the groove. Then click the front conrod onto the universal joint on the crank.

Note: The ball bearings are sealed for life and do not require oiling.

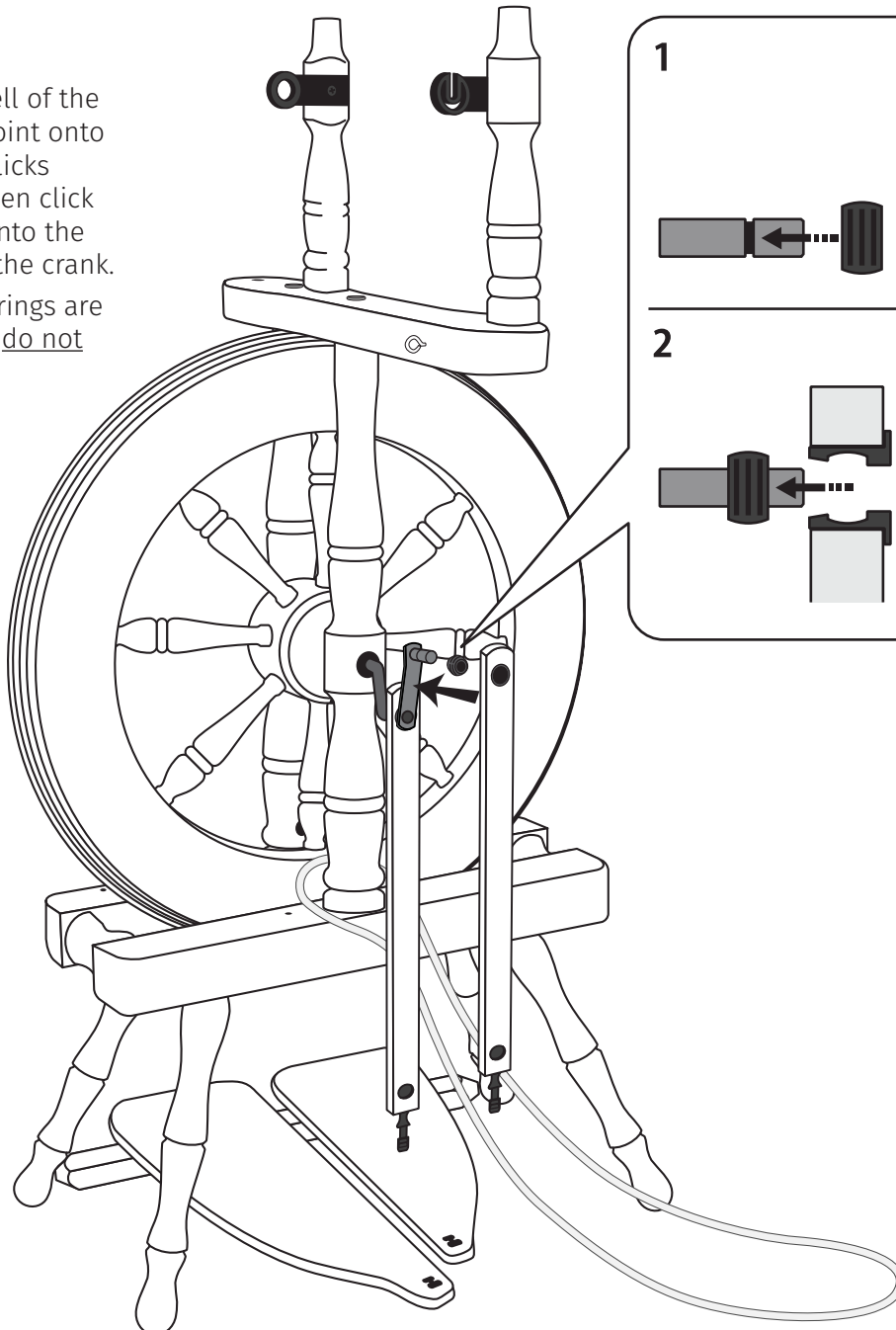

1

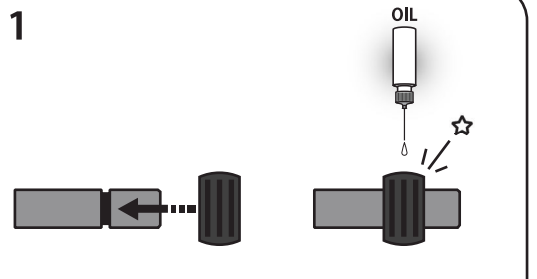

2

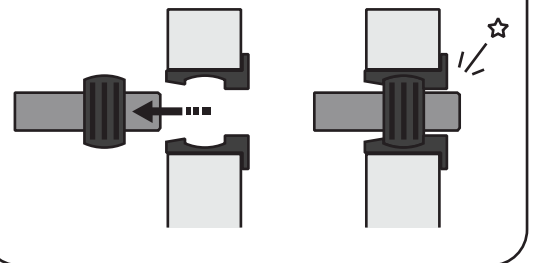

x1

15

Insert the outside conrod into the large slot in left hand treadle board.

1. Hold the conrod joint with one hand on either side of the treadle board.
2. With both hands, turn the conrod joint a ¼ turn.
3. Stretch and slide it into the small slot and turn it back a ¼ turn until it clicks into place.
4. Repeat the sequence for the inside conrod and right treadle board.

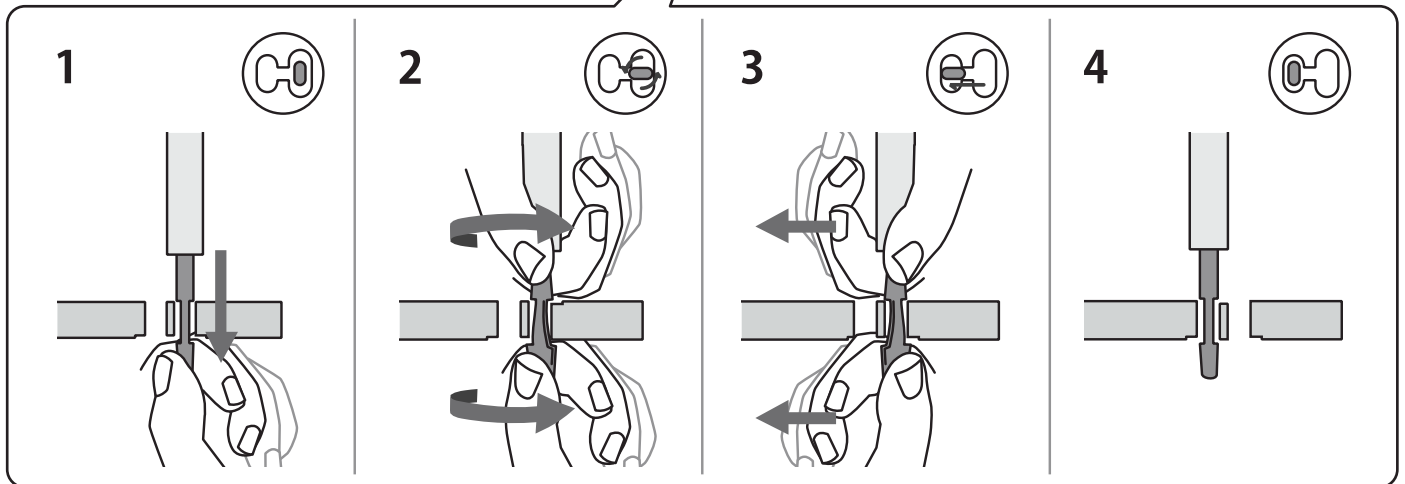
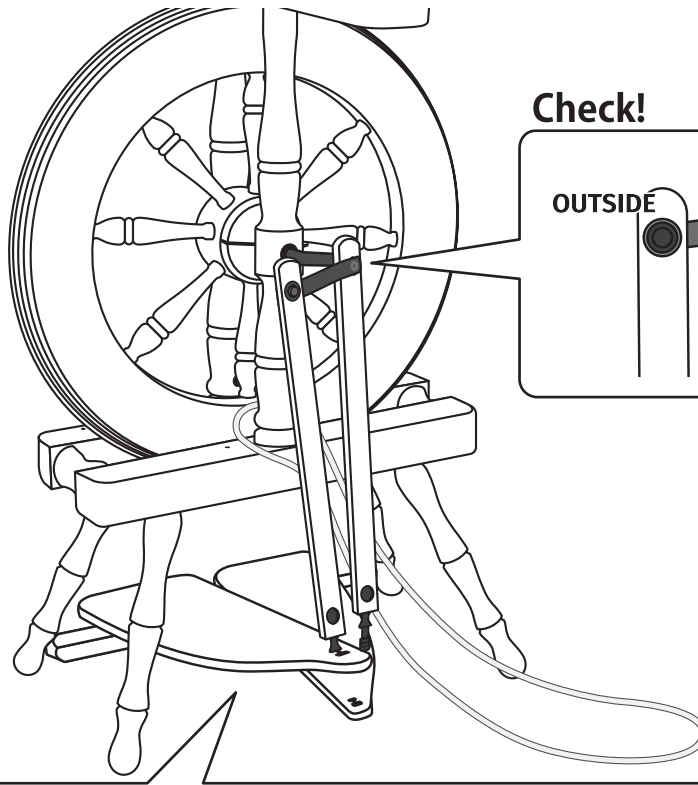

16



Thread 2 screw hooks into the flyer base. Squeeze and slide the stainless steel yarn guides onto the flyer arms. Apply a drop of oil to the flyer spindle and slide a bobbin on.

Ashford spinning wheel oil is ideal for this purpose. Locate the flyer between the flyer bearings.

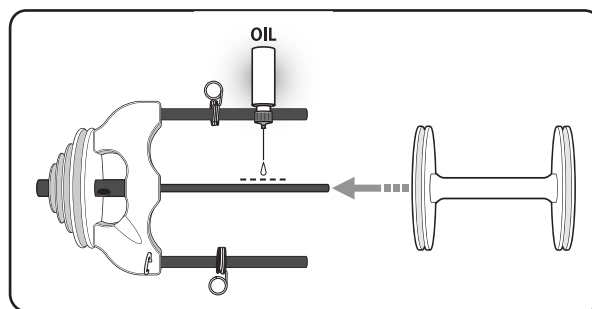
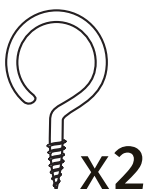

Check!

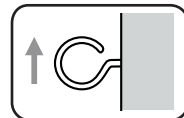

Check!

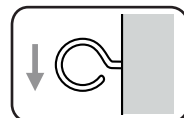

Check!

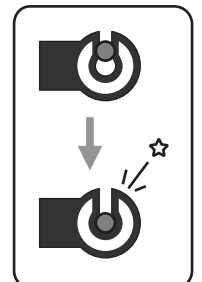

17



Cut 55cm (22") off the brake band. Thread it through the screw eye and attach the springs and tension knob as illustrated.

Place the brake band into the bobbin whorl groove. Do not over stretch the springs.

Locate the threading hook in the maiden bar.

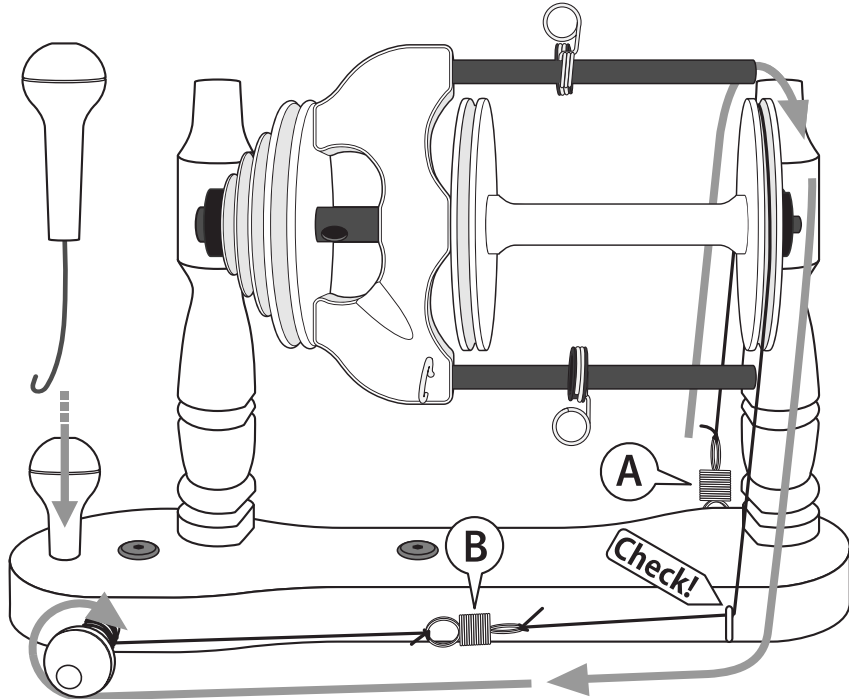
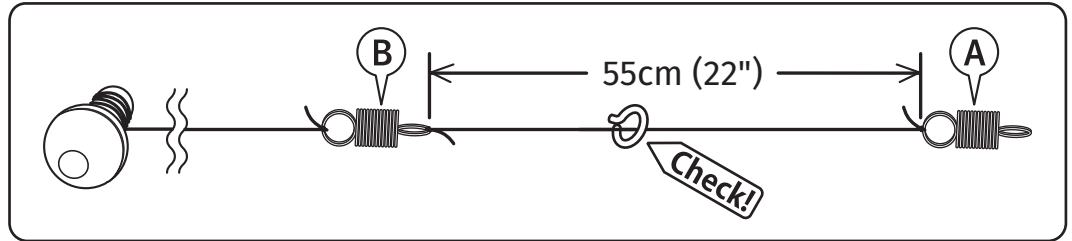

Check!

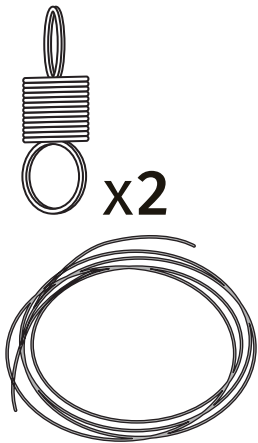
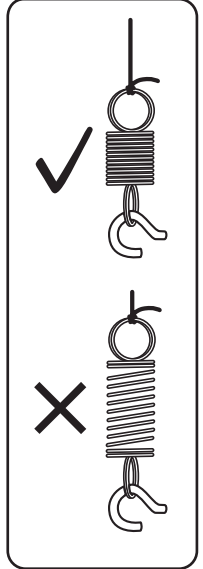

18

Position the stretchy drive band around the smallest grove in the wheel and then over the largest flyer whorl. This gives a flyer to wheel ratio of 5:1.

When changing ratios ensure the drive band directly aligns the wheel and flyer whorl.

Note

When not in use, always release the tension on the drive band by moving it to a smaller flyer whorl.

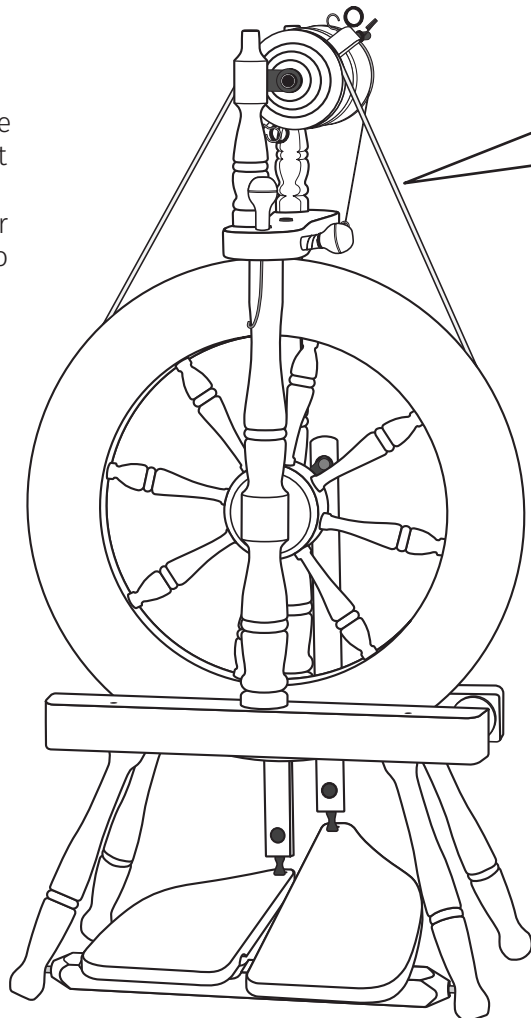

Ratios

When spinning coarse fibres or thick yarns use the slowest flyer speed of 5:1. For fine fibres and yarns use higher ratio.

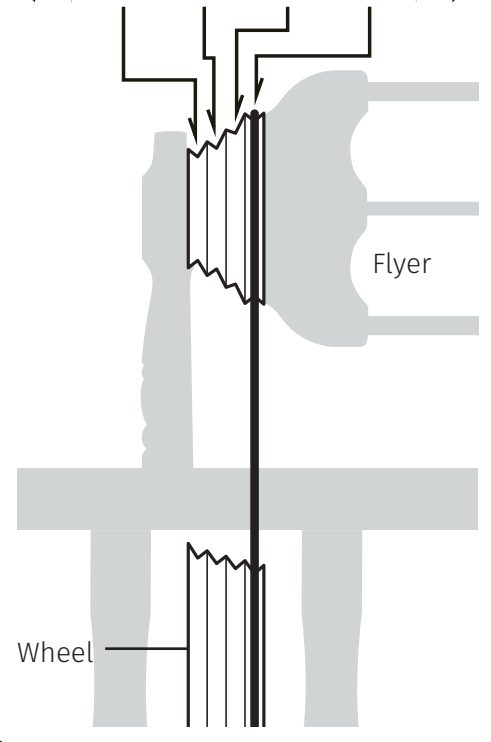

19 

Tap the lazy kate pins into the base and locate the spare bobbins on them.

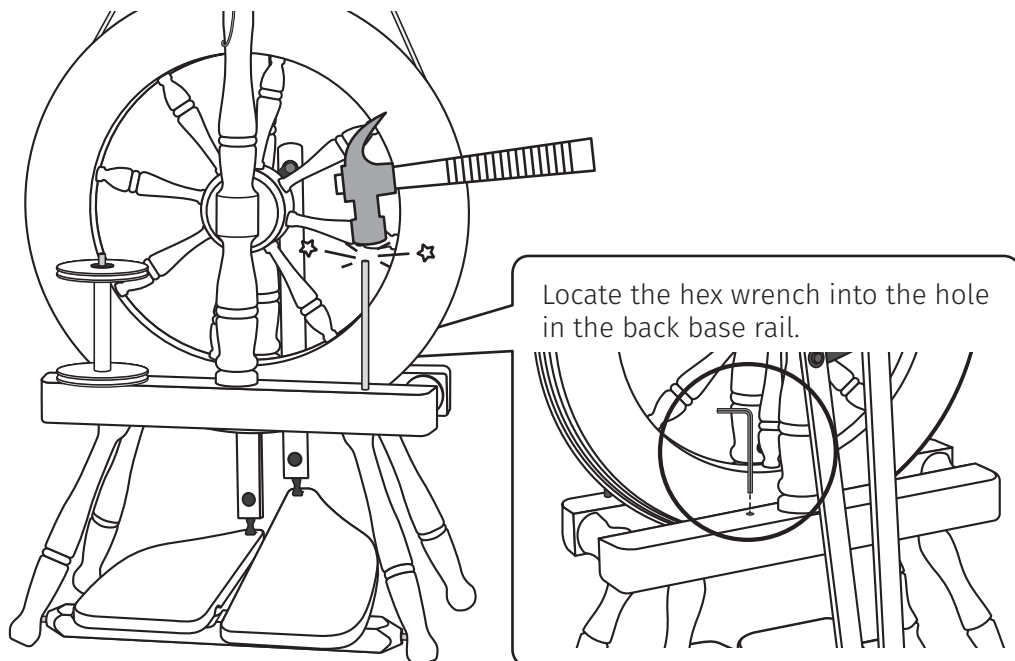

20 

Oil all points on the Spinning Wheel before use as illustrated.

Note: The ball bearings are sealed for life and do not require oiling.

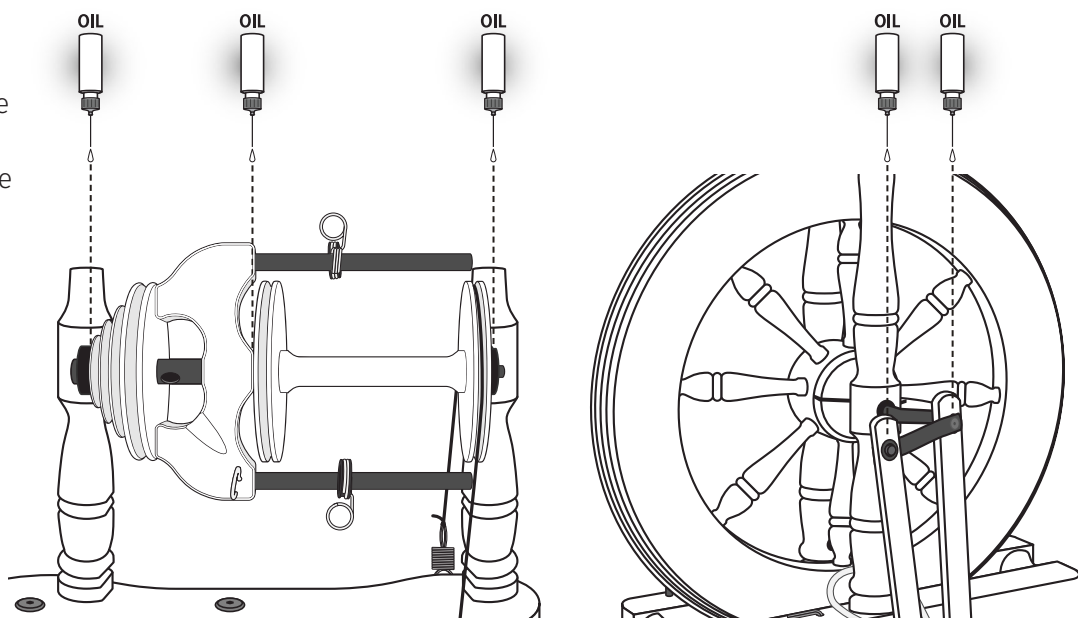

21

Tie a piece of yarn called a leader, approx. 1.5m (5') long, to the bobbin.

Thread it through the yarn guide, around the flyer hook and pull through the orifice with the threading hook. The Learn to Spin on an Ashford Wheel booklet will guide you on your spinning journey.

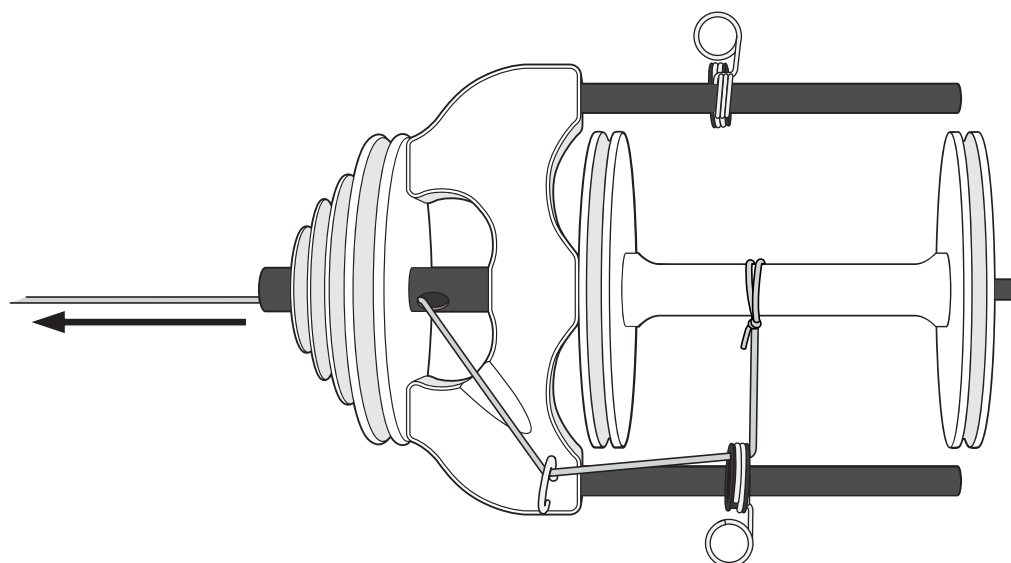

*For further spinning and plying information refer to "The Ashford Book of Hand Spinning" by Jo Reeve, a 116 page book full of ideas and inspiration for spinners or visit our website www.ashford.co.nz

Solutions

If the yarn doesn't pull in:

Check!

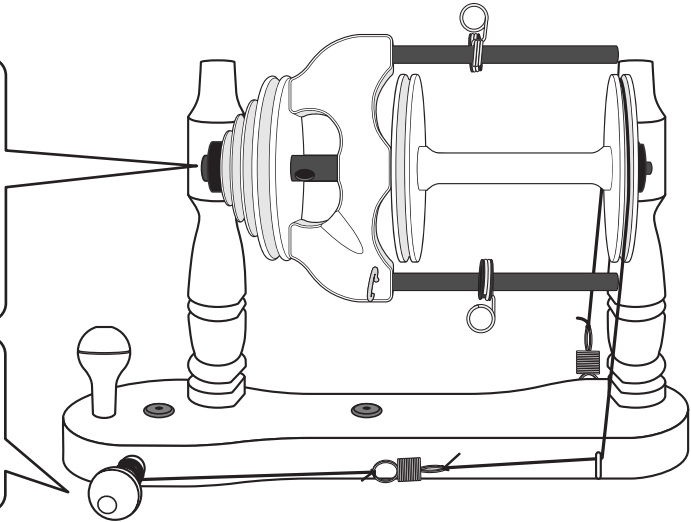
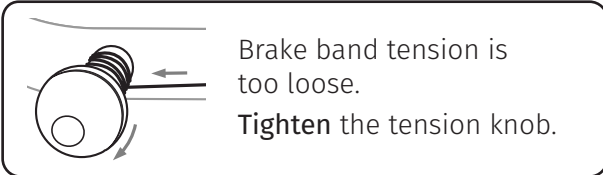
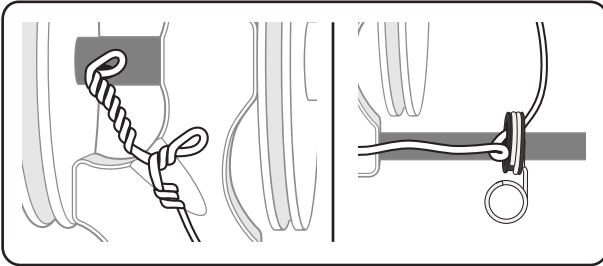

If the yarn breaks:

Check!

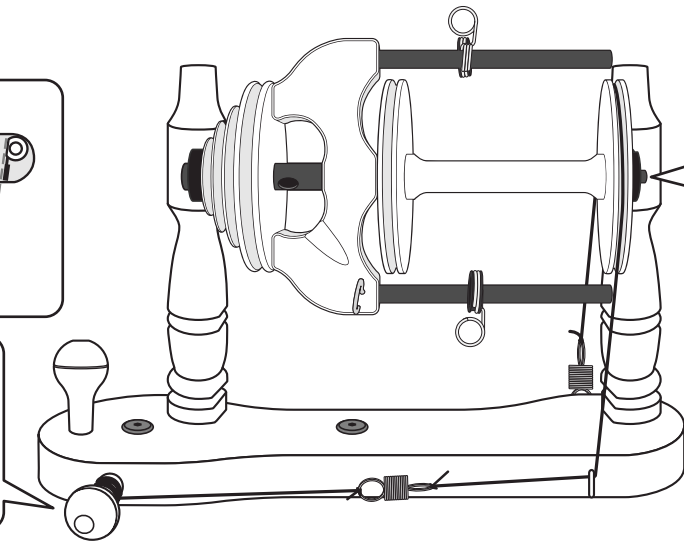
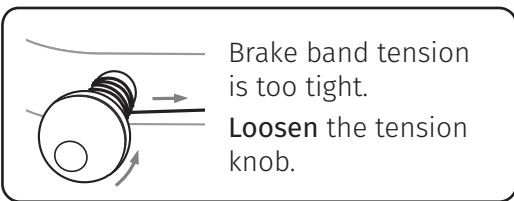
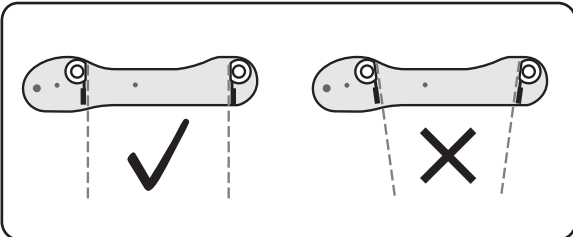

Check!

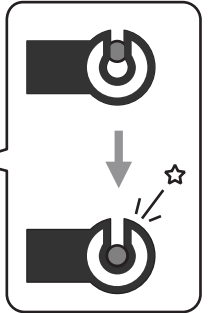

If the drive band falls off easily:

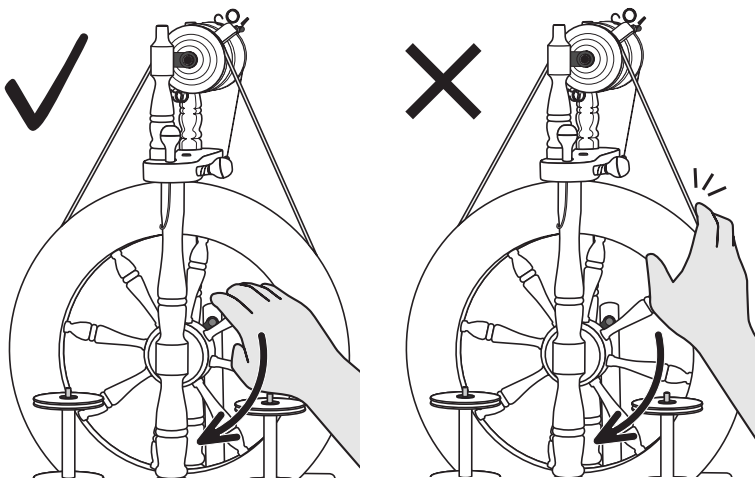

Check!

