

WINDING STATION

WW7941

ASSEMBLY INSTRUCTIONS

PARTS

- 1X thread guide shelf
- 2X cone holders
- 2X bases
- 2X uprights
- 2X metal spool rods
- 1X top

TOOLS

- hammer or mallet
- #2 Phillips screwdriver
- slotted (flat) screwdriver
- 4" steel rod (included; to install or adjust screw eyes)

ASSEMBLY

1. Attach four screw eyes to each long edge of the thread guide shelf, as shown in Figure 1. Start each screw eye in the pre-drilled holes by hand, then use the 4" steel rod to tighten them parallel to the shelf top.
2. Install a short metal rod in each of the holes on the cone holders, as shown in Figure 1. Set the shelf on a flat surface and tap the rods firmly into place with a hammer or mallet.
3. Orient the bases so the oval holes face inward, as shown in Figure 1. Attach the two cone holders to the bases using a 1/4-20 x 2" Phillips truss head screw and a 1/4-20 barrel nut at each end.
4. Attach the uprights to the bases using a 1/4-20 x 3-1/2" Phillips truss head machine screw and a 1/4-20 barrel nut.

HARDWARE

- 8X screw eyes
- 8X short (7-1/2") metal rods
- 12X 1/4-20 barrel nuts
- 8X 1/4-20 x 2" Phillips truss head machine screws
- 2X 1/4-20 x 3-1/2" Phillips truss head machine screws
- 4X cotter pins
- 2X 1/4-20 x 3-1/2" slotted flat head machine screws

5. Insert the metal spool rods in the uprights, leaving about 1/2" of rod extended on each side. Push a cotter pin about halfway into the hole at the end of the rod, leaving a loop at the top (Figure 2).
6. Attach the thread guide shelf to the uprights using two 1/4-20 x 2" Phillips truss head screws and two 1/4-20 barrel nuts at each end. If you wish to adjust the screw eyes, use the 4" steel rod and work carefully so the eyes don't break.
7. Attach the top to the uprights using a 1/4-20 x 3-1/2" slotted flat head machine screw and a 1/4-20 barrel nut at each end. ■

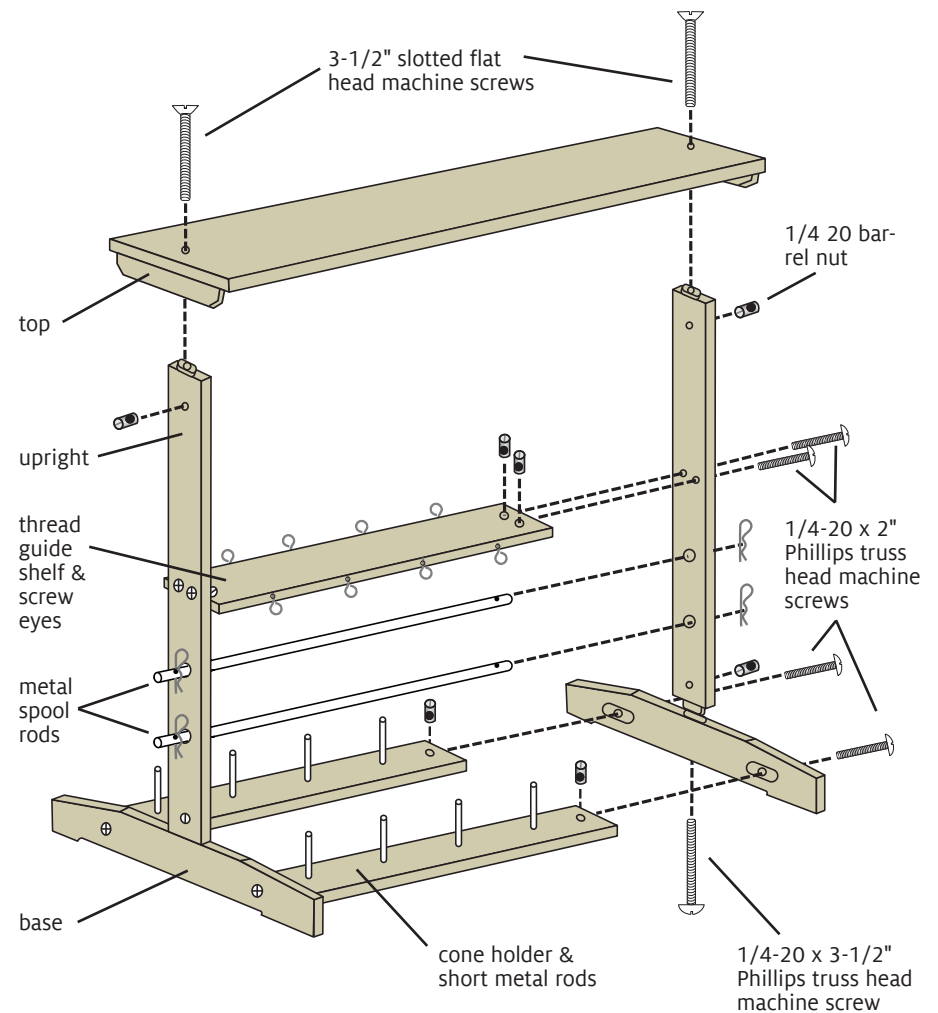

FIGURE 1: WINDING STATION ASSEMBLY

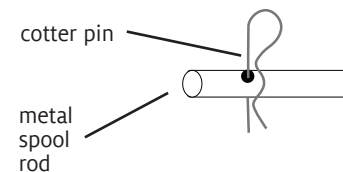
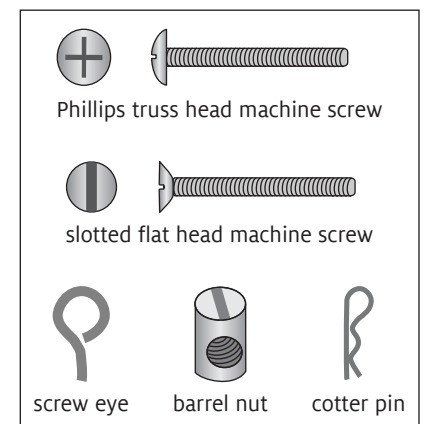

FIGURE 2: COTTER PIN INSTALLATION



Find out more at schachtspindle.com
Schacht Spindle Company 6101 Ben Place Boulder, CO 80301
p. 303.442.3212 800.228.2553 f. 303.447.9273
© 2019 Schacht Spindle Company, Inc.

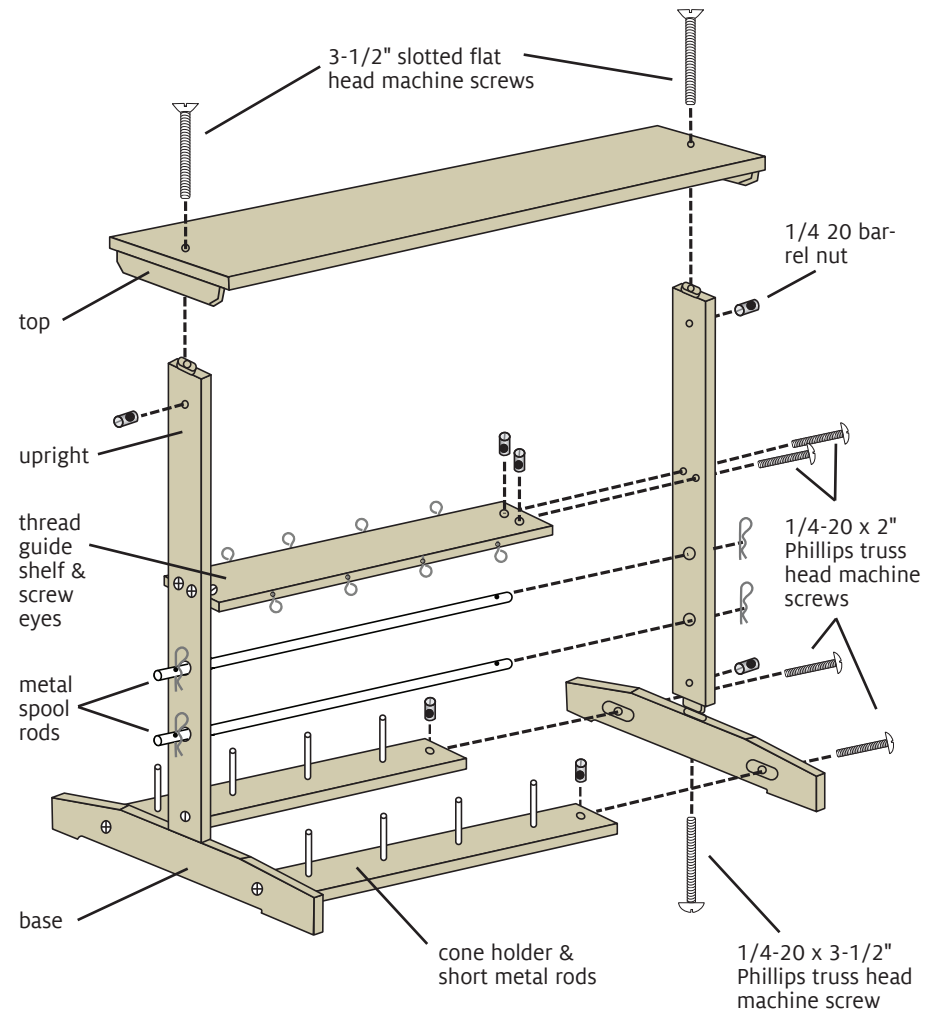

FIGURE 1: WINDING STATION ASSEMBLY

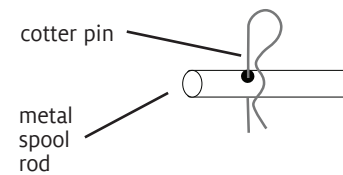

FIGURE 2: COTTER PIN INSTALLATION

