

ASHFORD TRADITIONAL SPINNING WHEEL SINGLE DRIVE

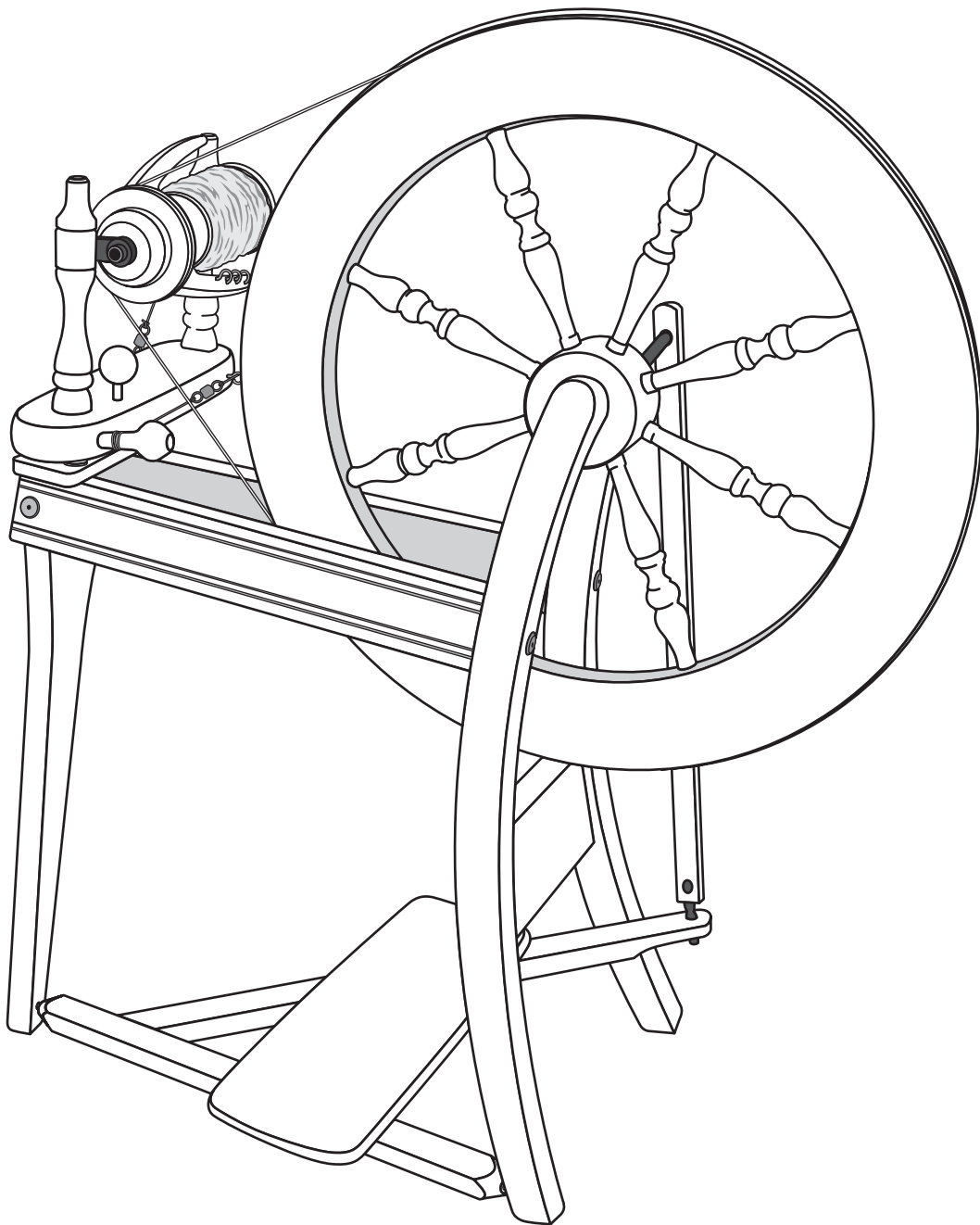

TDSW110618V11

ASSEMBLY INSTRUCTIONS FOR THE ASHFORD TRADITIONAL SPINNING WHEEL -Single Drive-

Before commencing, please read these instructions completely, identify the parts and note the assembly sequence.

Remove any sharp corners or edges and smooth the surface of the wood with the sand paper provided. We recommend that the wood surfaces be waxed or sealed before assembly. This protects the kiln dried wood from the climatic changes and prevents it getting dirty or stained. The Silver Beech tree is a native of New Zealand and has a lovely variety

of colour and grain. For a silky smooth matt finish, use the Ashford Wax Finish to enhance the natural colours and character of this timber.

If you are assembling your spinning wheel on a table, we recommend you protect the surface with a towel, blanket or cardboard. Ashford spinning wheels are also available factory finished in clear lacquer.

Tools Required



Hints

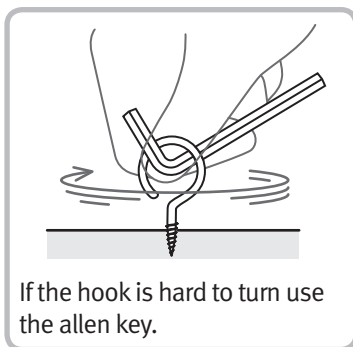
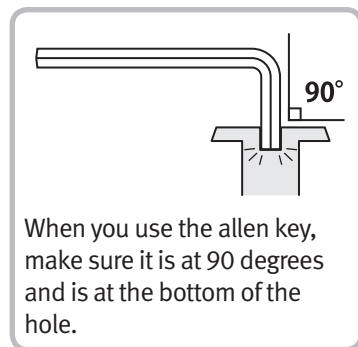
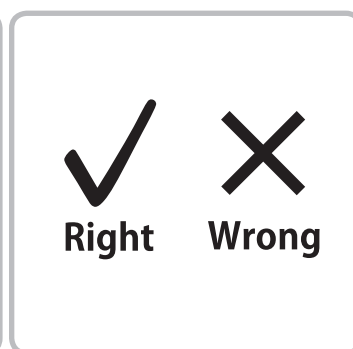
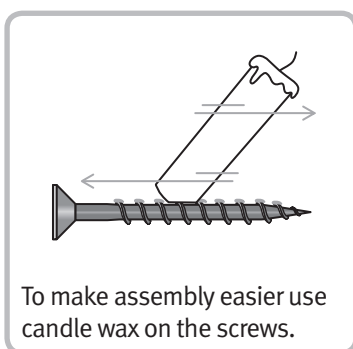
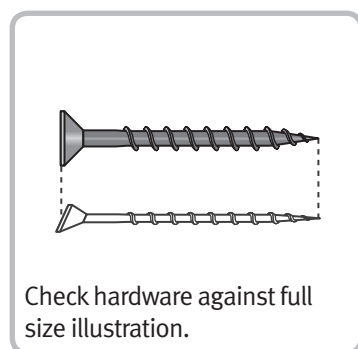

More Information



How-to videos on You Tube
Watch our how-to videos on You Tube.
www.youtube.com/user/AshfordHandicrafts



Facebook
Join us on facebook.
www.facebook.com/ashford.wheels.looms

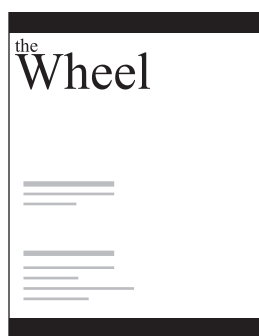

The Wheel Magazine
Ashford's annual fibrecraft magazine. Spinning, weaving, felting, dyeing and knitting projects, patterns and articles from around the world. To receive the glossy version delivered to you, subscribe at:
www.ashford.co.nz/subscribe

Real Scale Hardware List

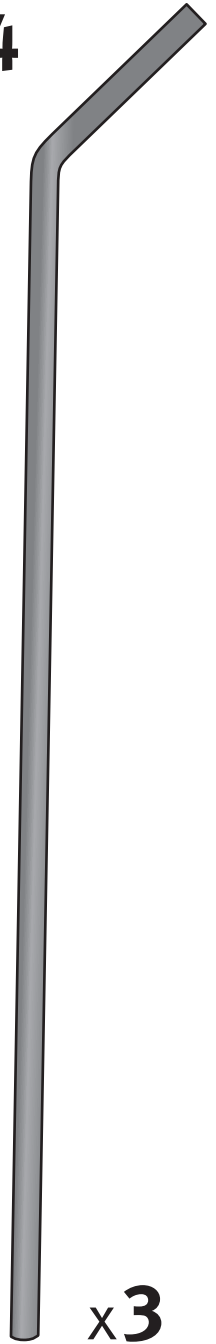
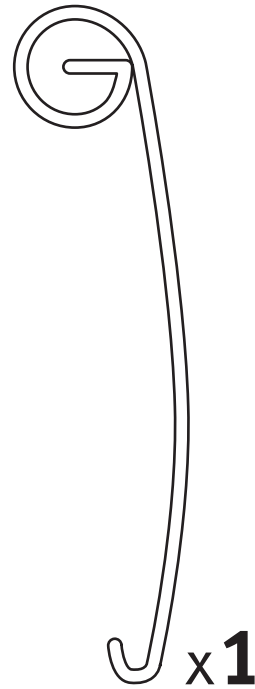
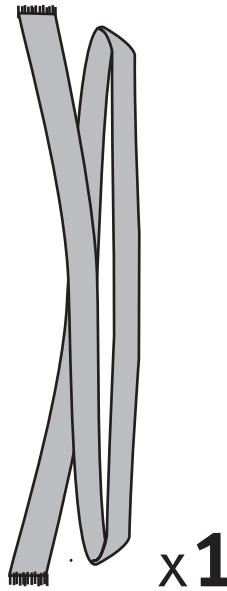
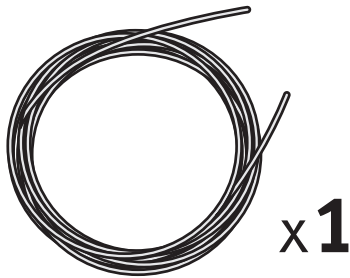
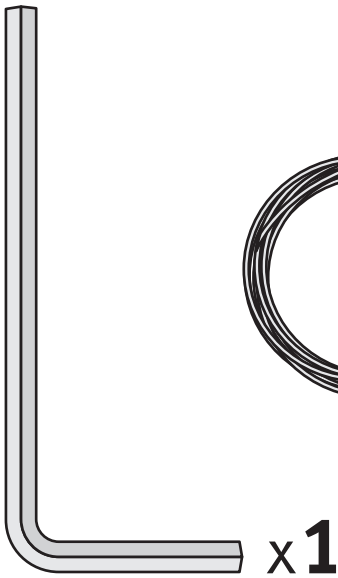
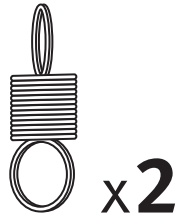
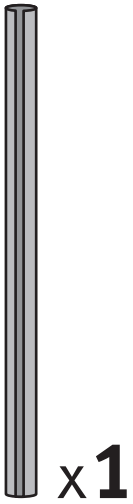
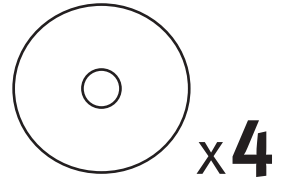
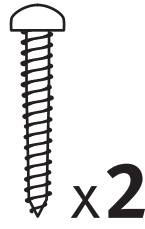
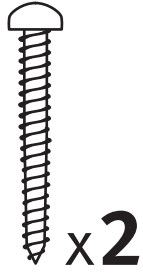
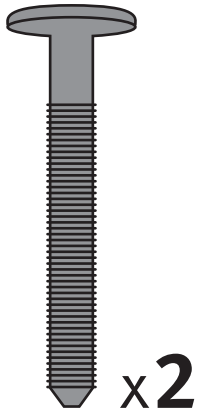
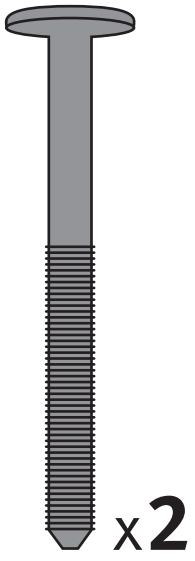
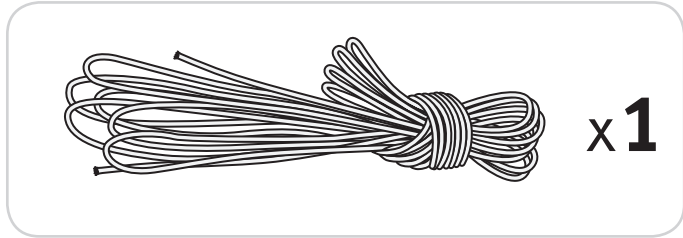

1

Assemble the Lazy Kate.
Note - the holes with countersunk holes on each upright face inwards.

Check!

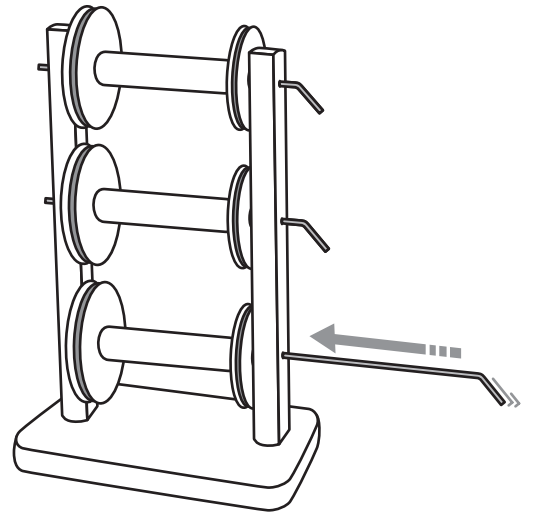
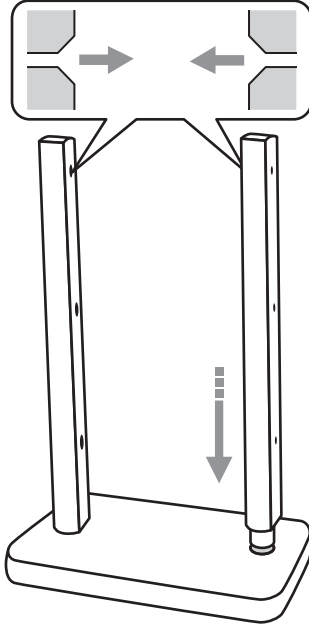

2



Thread 12 hooks into the flyer.

Check!

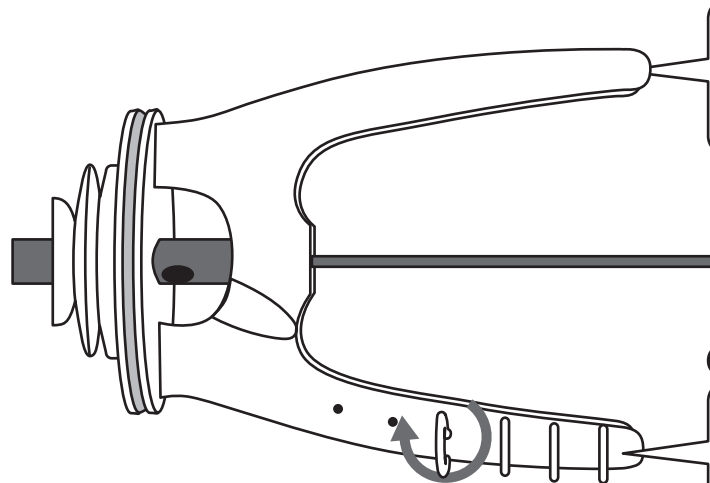

Check!

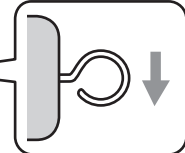

3



Assemble the flyer unit.
Check the shape of the nylon bearing on each maid upright, wax the dowel ends, then insert into the correct hole.
Insert the drive belt adjusting knob into the maiden bar, turn until the end just protrudes.

Check!

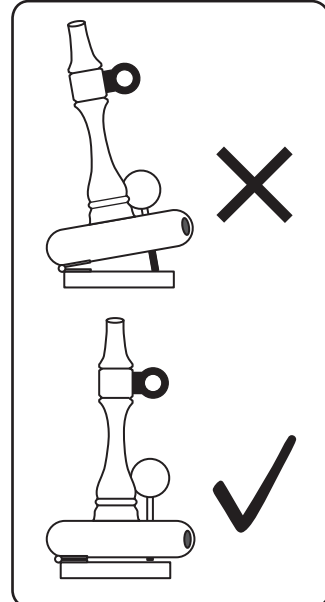

Check!

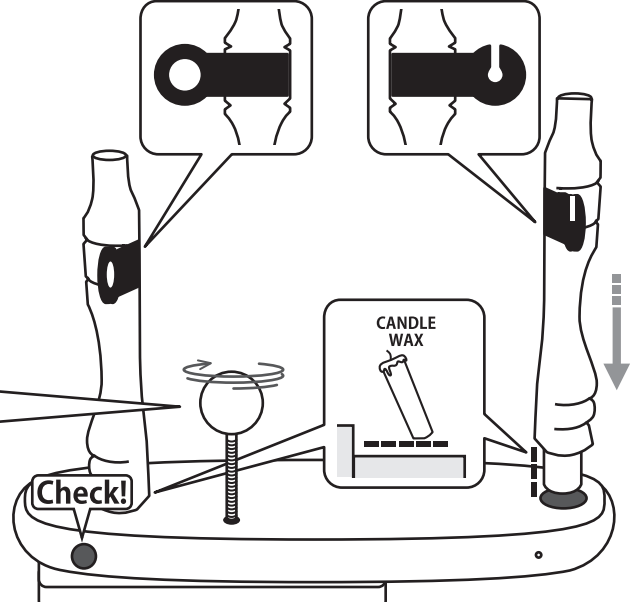



Check the angle of the nylon bearings. Then secure the maid uprights with screws and washers. Do not overtighten. The maid uprights may be twisted to remove the bobbin. Position the drawing pin directly beneath the drive band adjusting knob.

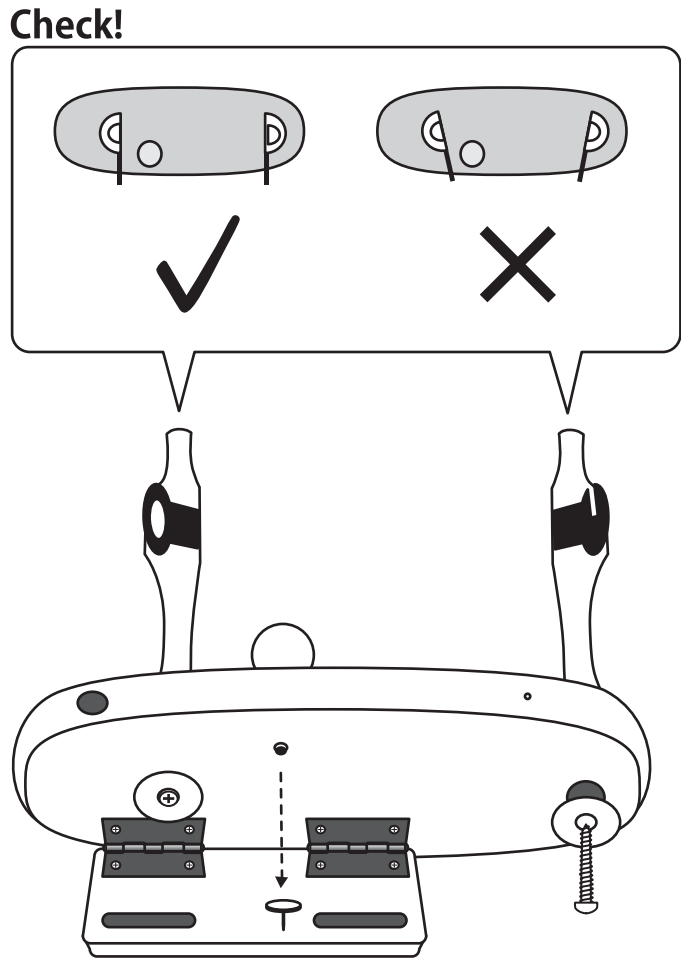
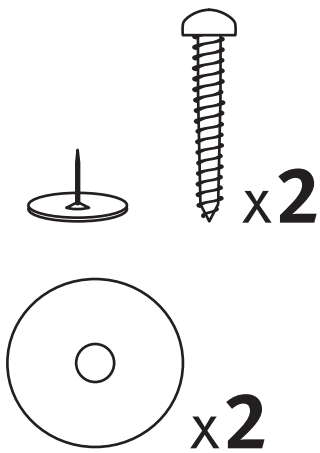

Place the bobbin, small end first, onto the flyer. Then locate the flyer into the bearings. Thread the screw eye into the side of the maiden bar, and screw hook into the opposite side.

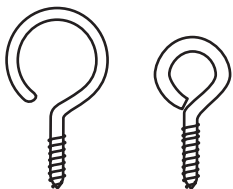
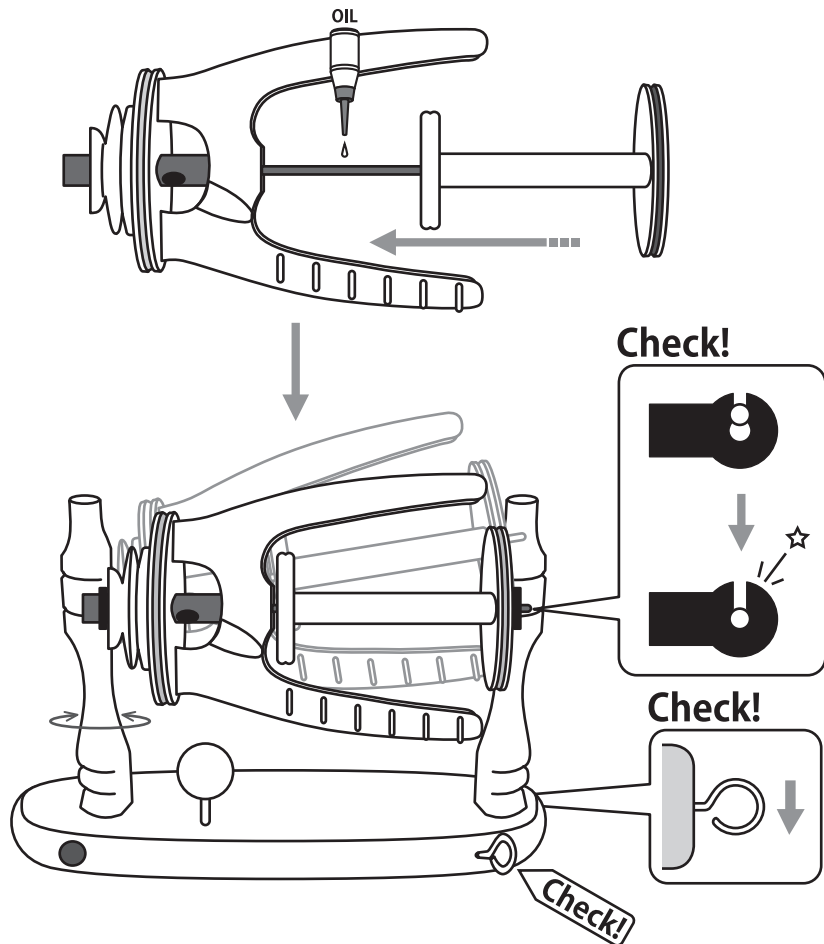

6



Attach the brake band.
Thread it through the
screw eye and then tie the
springs as illustrated.

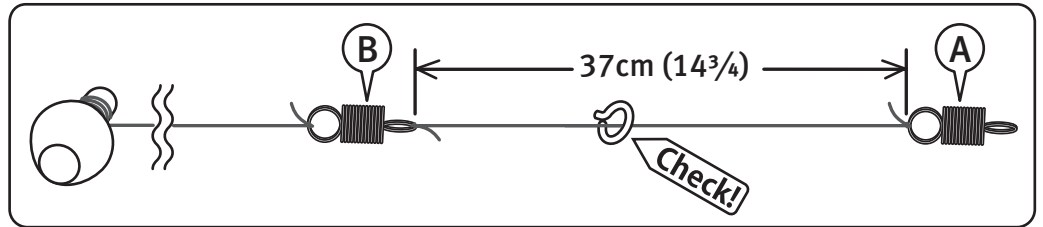
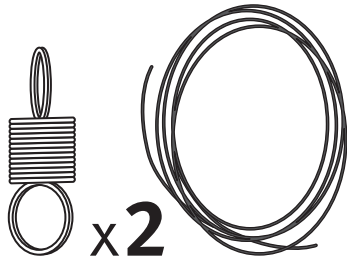
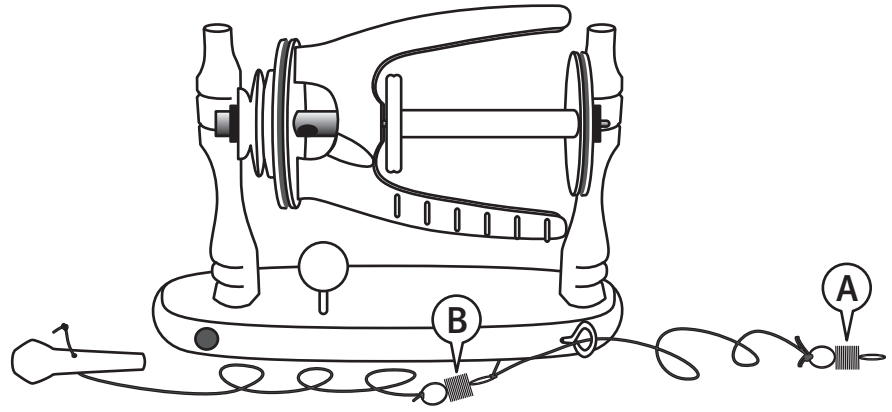

7



Put the brake band over
the grooved end of the
bobbin.
Do not over stretch the
springs.

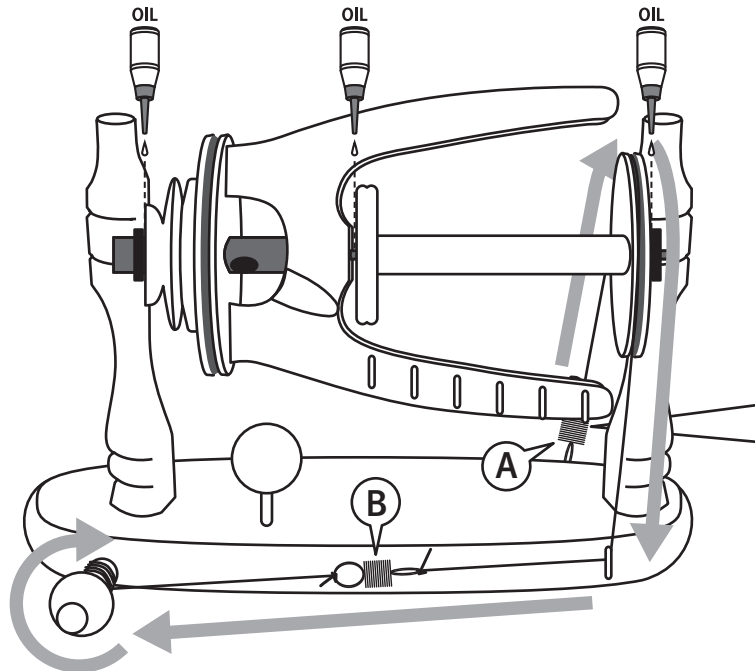

Check!

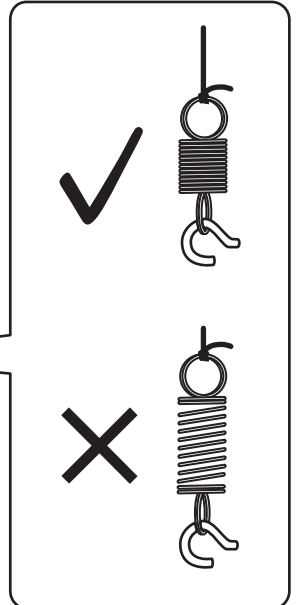

8

Tie the threading hook
to the front maid upright
with tape.

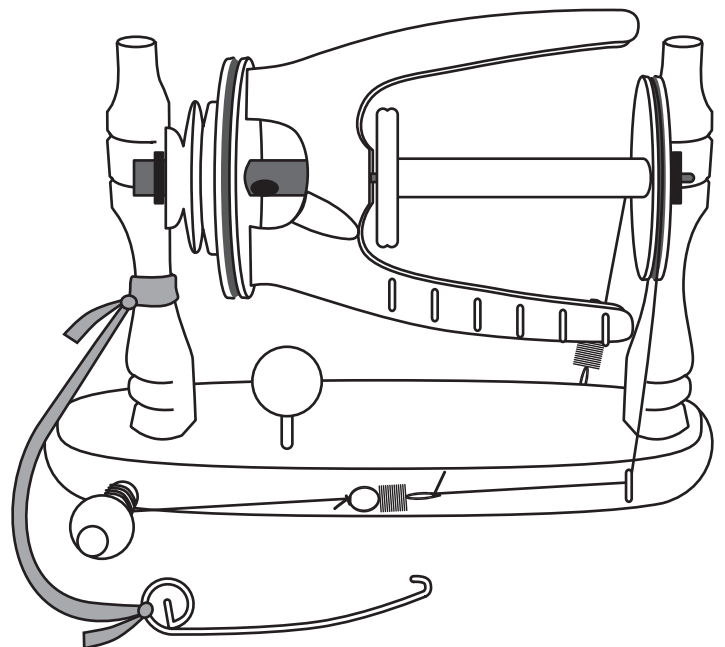
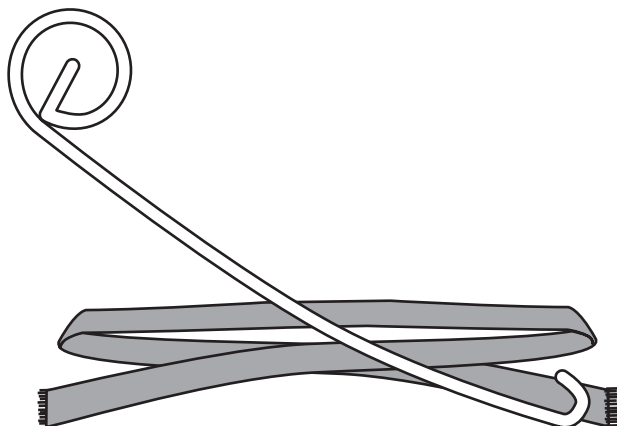

9



Check the small hole is on the top of the side rails. Attach the side rails to the single leg with bolts and barrel nuts.

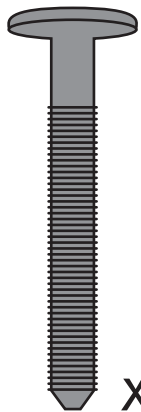
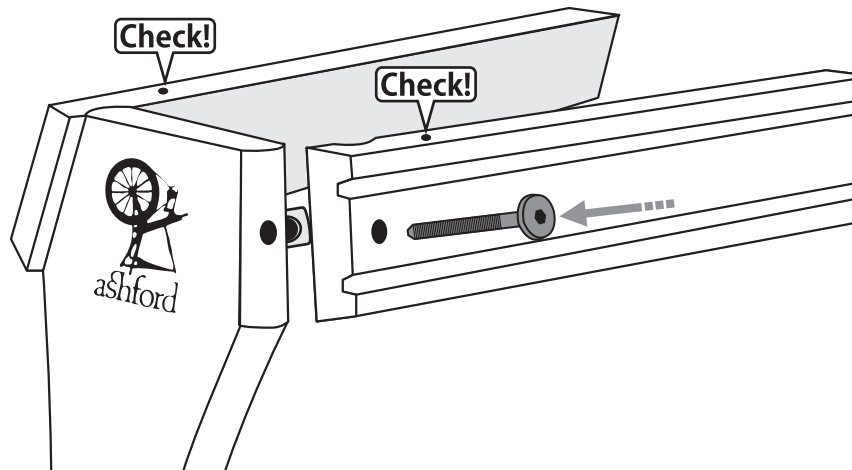

x2



x2

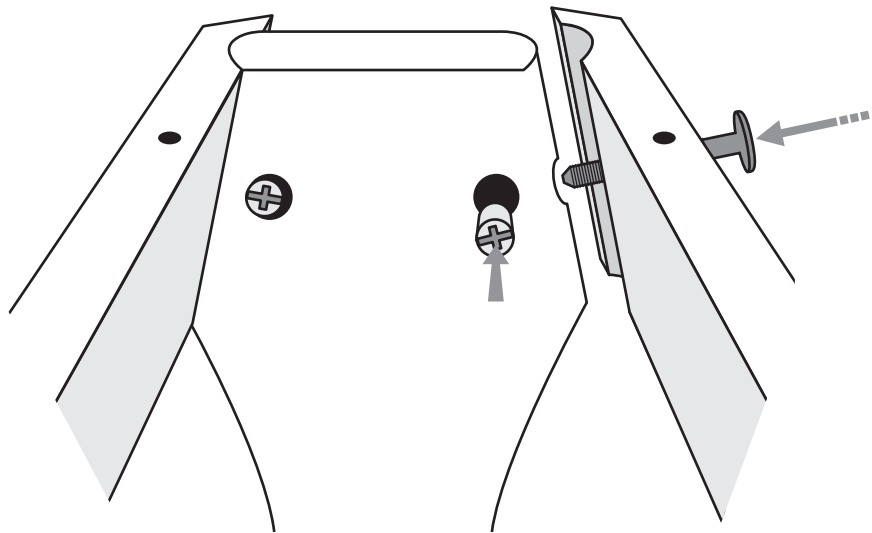

10



Check the angle of the side rails and tighten.

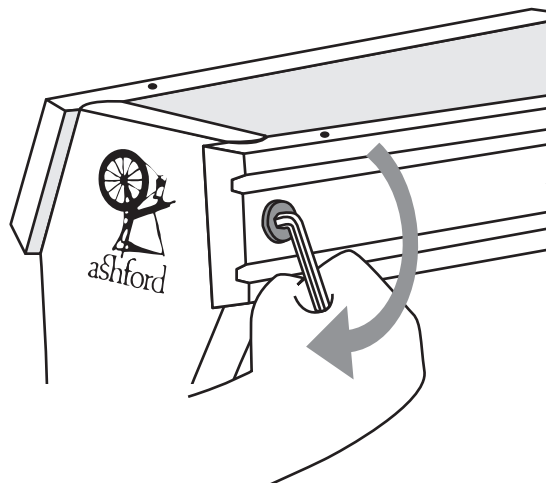

Check!

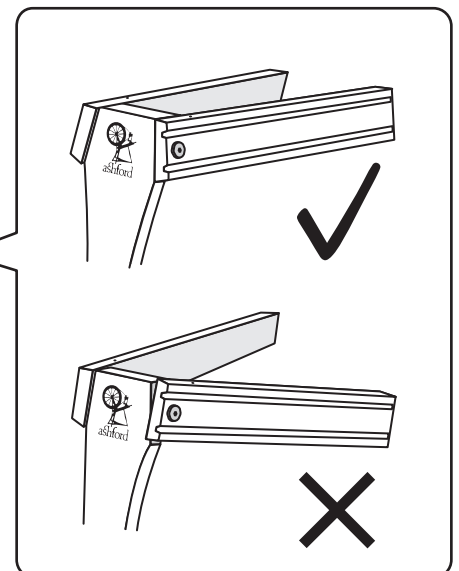

11

Set the treadle assembly on the edge of a table. Insert the conrod joint into the large slot in the treadle rail. Note the crank bearing faces the back of the spinning wheel.

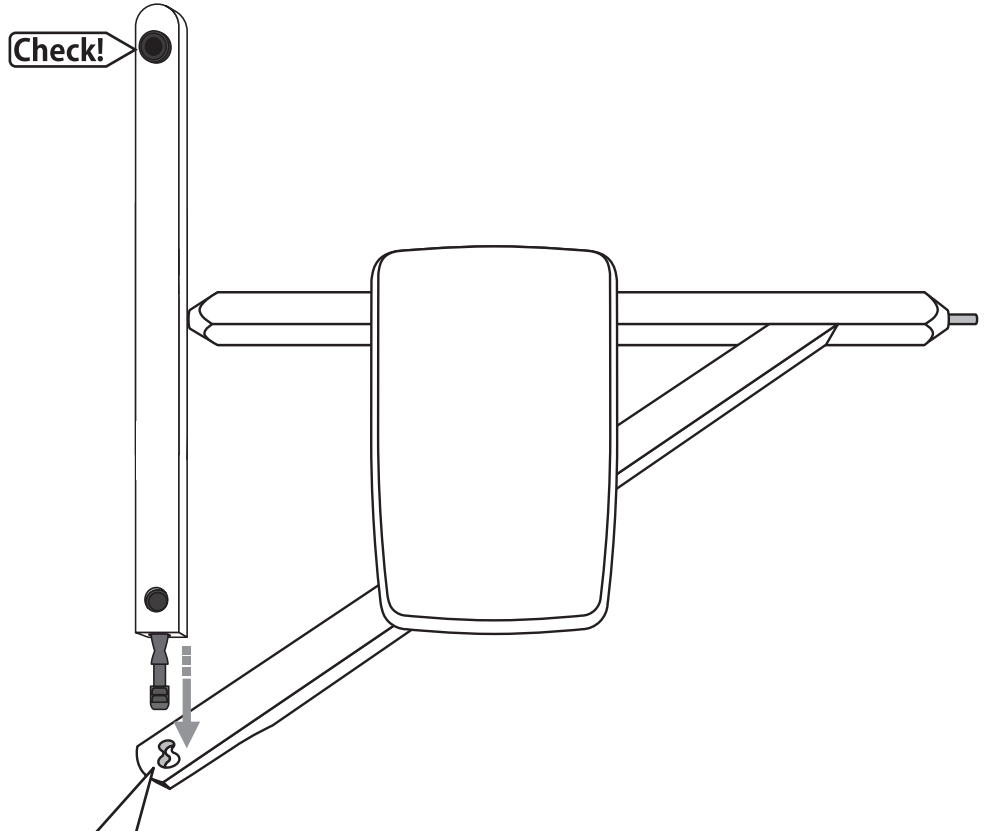

1

Hold the conrod joint with one hand on either side of the treadle rail.

2

With both hands, turn the conrod joint a $\frac{1}{4}$ turn,

3

stretch and slide it into the small slot and turn it back a $\frac{1}{4}$ turn until it clicks into place.

4

12



Wax the steel rods in the treadle rail.

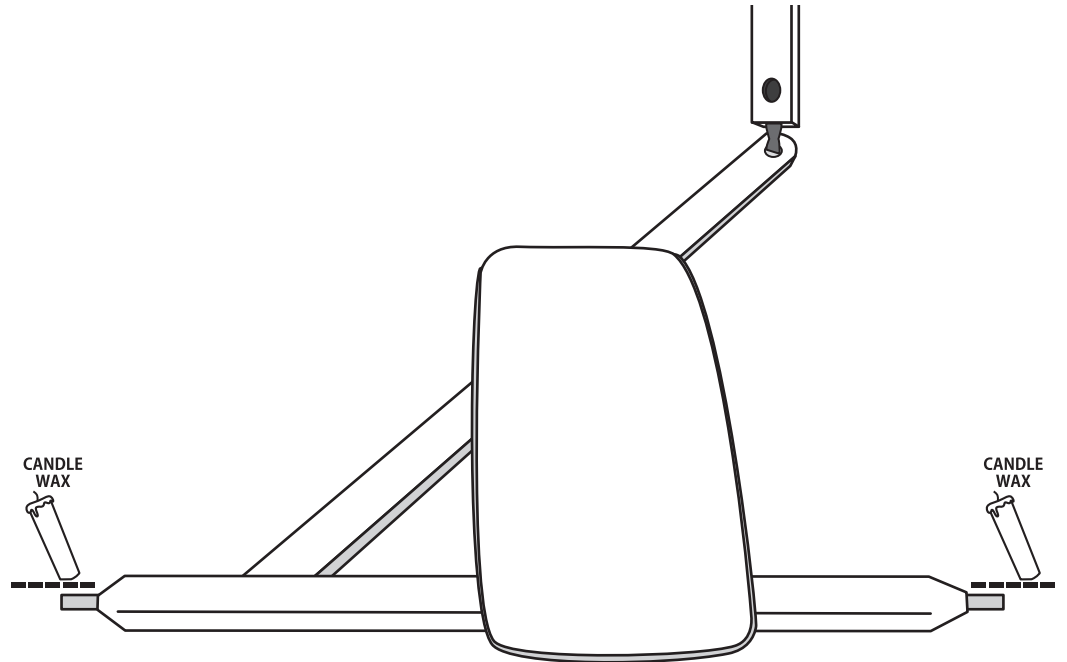

13



Loosely attach the wheel support to the side rails with bolts and barrel nuts. Then locate the treadle rail into the holes in the legs

Check!

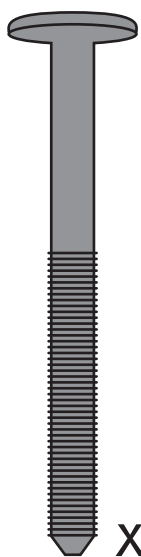
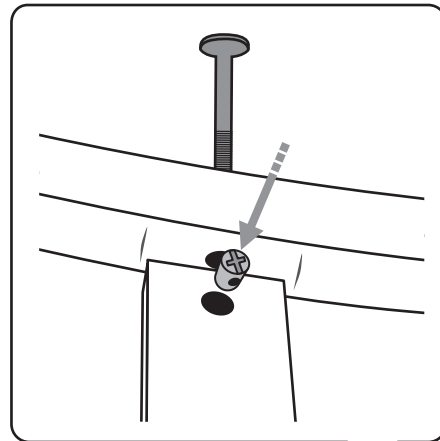

x2



x2

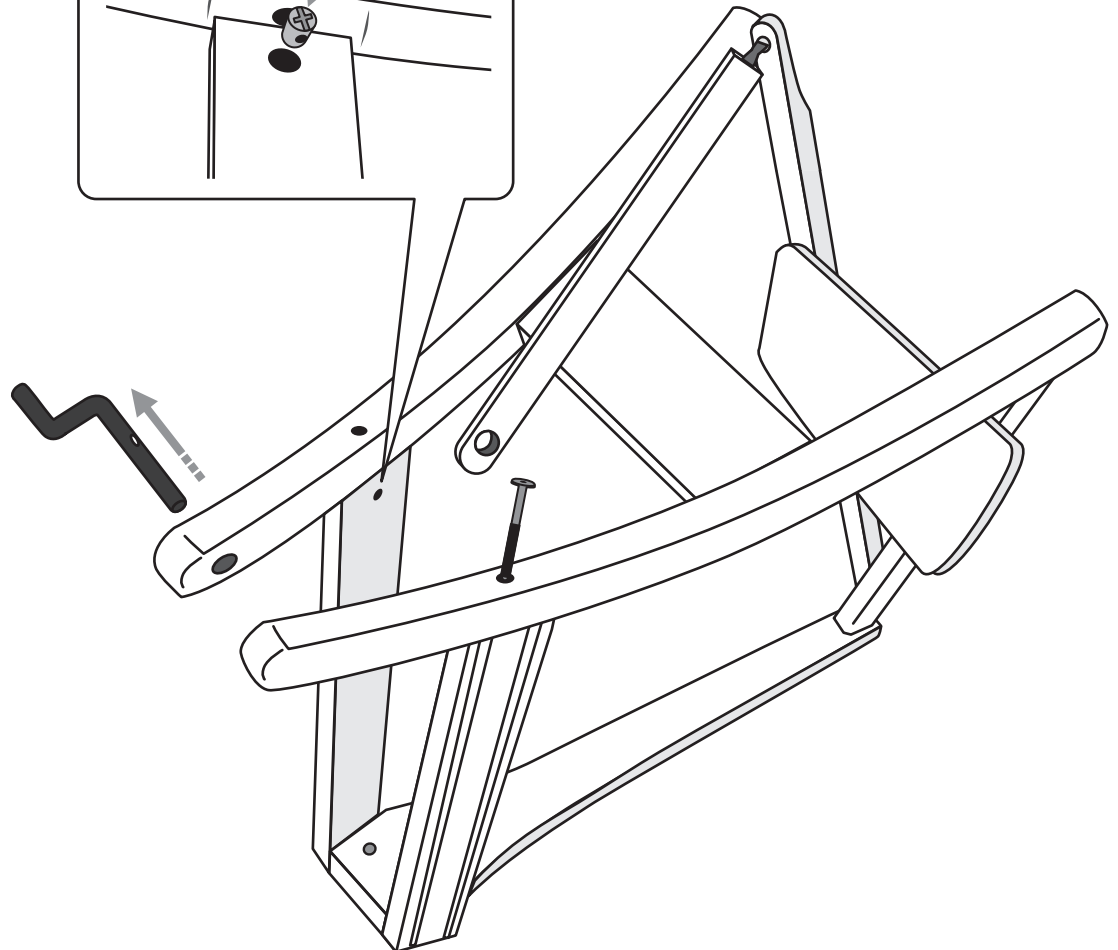

14

Check the angle of the single leg.

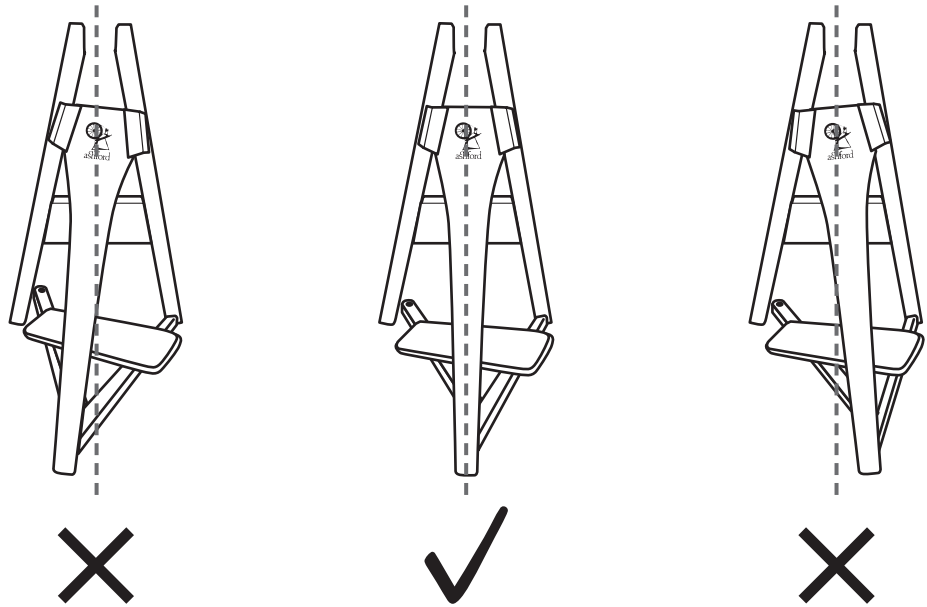

15



Insert the crank shaft into the wheel support. Tighten every bolt extra firmly with the allen key.

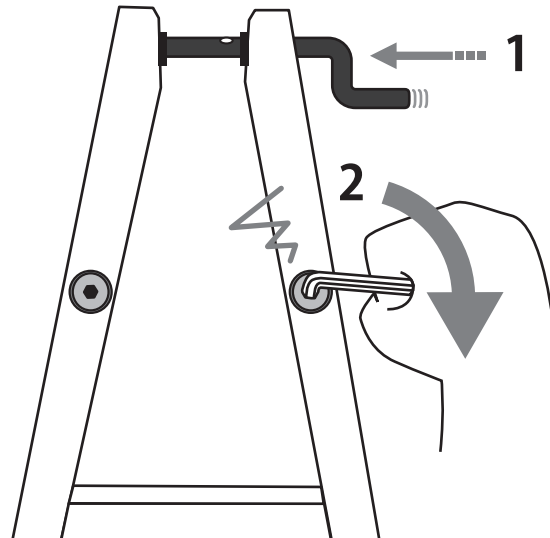

16



Before placing the wheel in position, check the crank fits through the hole in the hub. Wax and insert the crank shaft then remove.

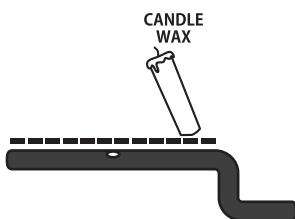

Check!

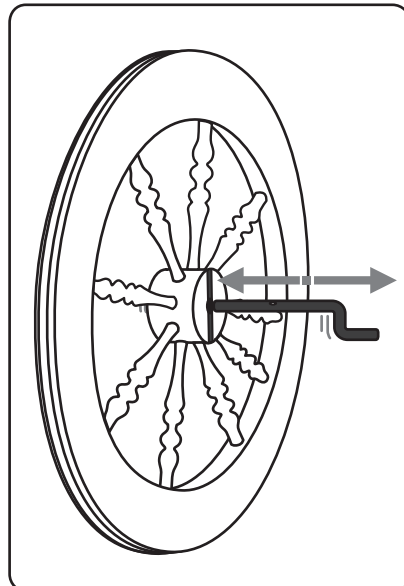

Place the wheel in position.

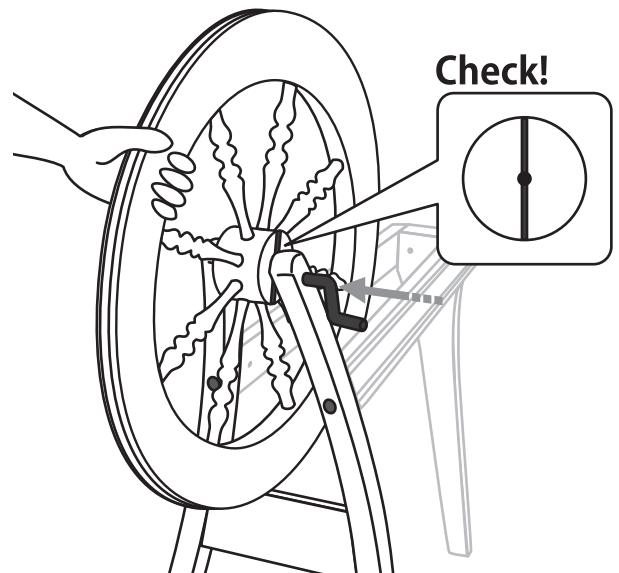

17

Align the wheel and hole in the crank shaft with the groove in the hub using a lazy kate wire.

Check!

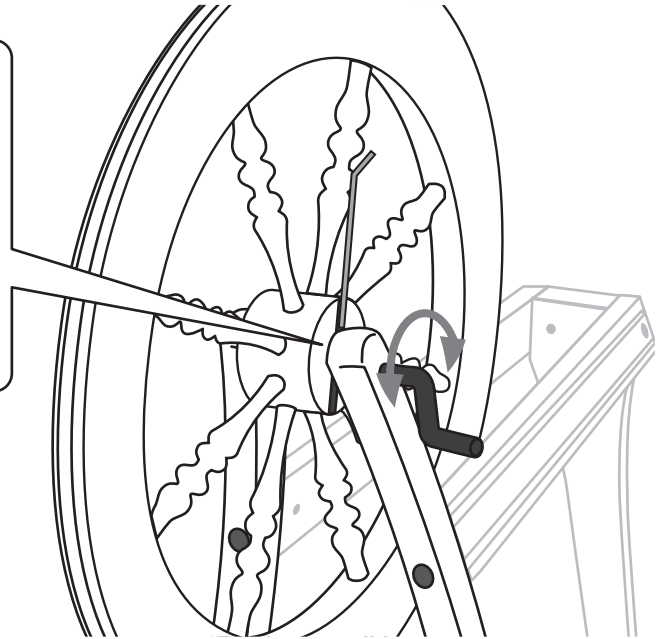
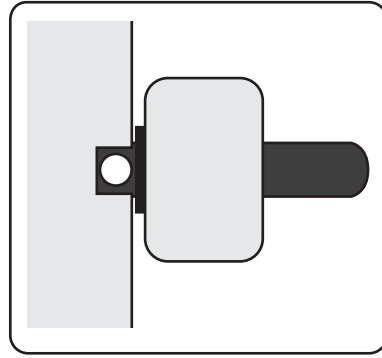

18



Carefully tap the hub pin through the hub and crank.

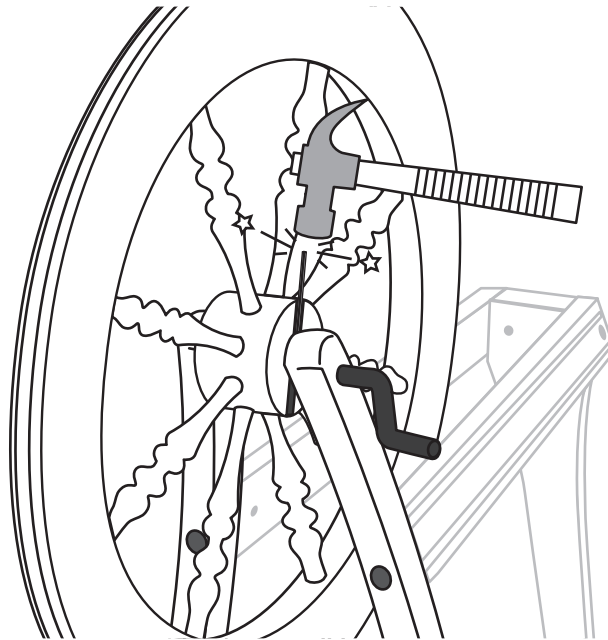
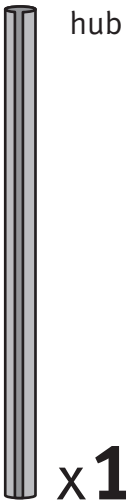

Check!

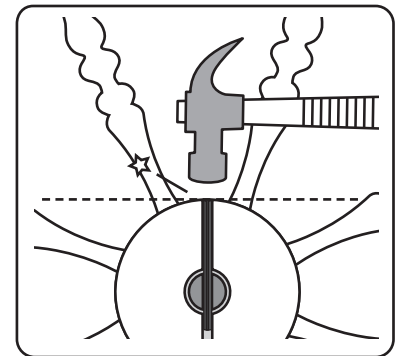

19



Slide the inner shell of the conrod universal joint onto the crank until it clicks into the groove. Apply a drop of oil to this bearing and click the conrod onto the inner shell of the conrod joint. Note: The ball bearings are sealed for life and do not require oiling.

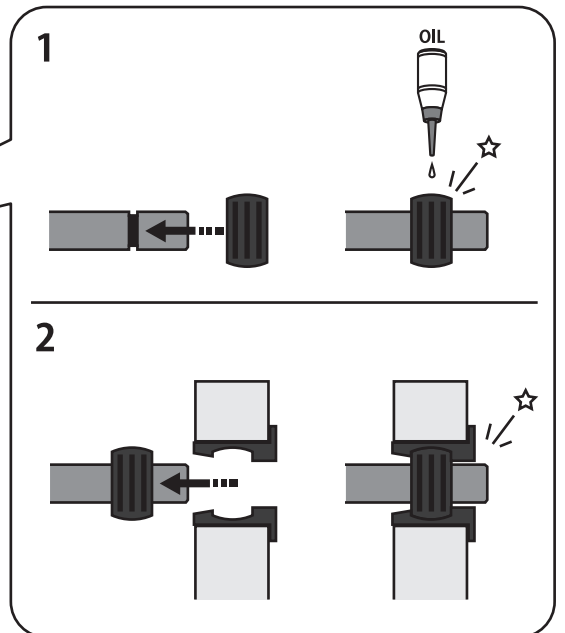
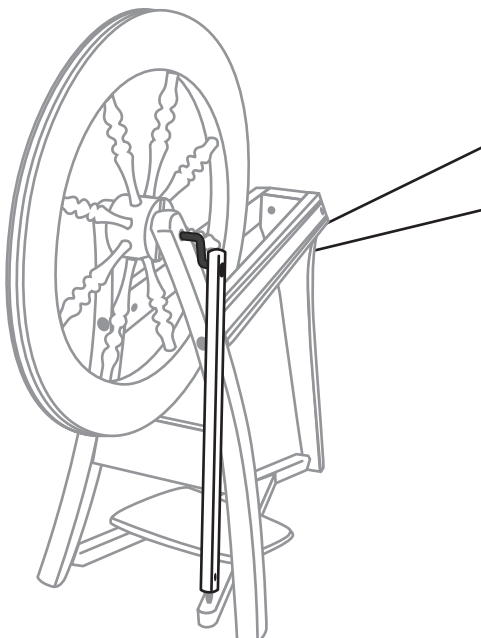

20



Attach the flyer unit to the side rails with 2 screws and washers, do not tighten yet. Move the flyer unit until the wheel and large flyer pulley are aligned. Then tighten the screws.

Check!

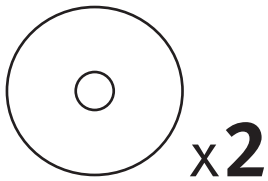
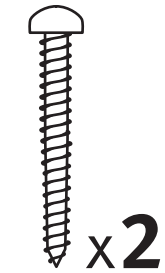
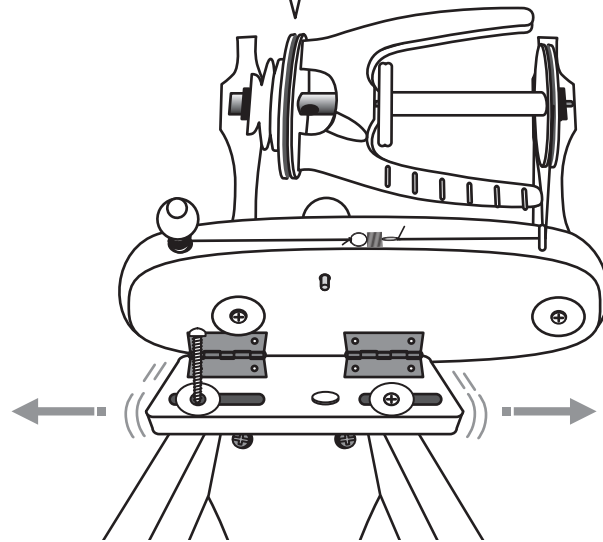
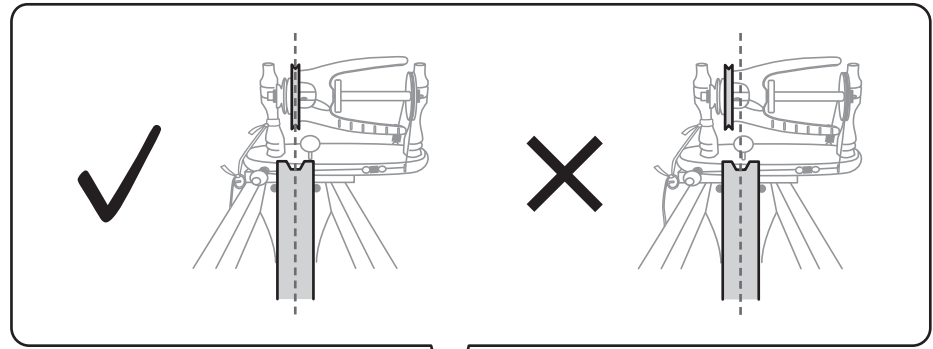

21



Check the end of the adjusting knob is not protruding beneath the maiden bar. Then place the drive belt around the wheel and large flyer pulley. Tie the drive belt and cut off the extra.

Check!

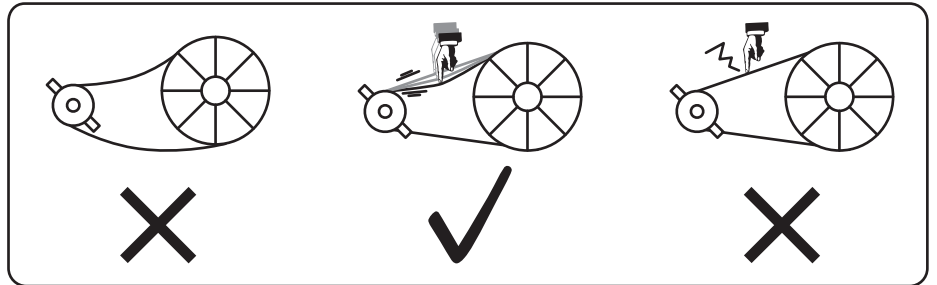

Check!

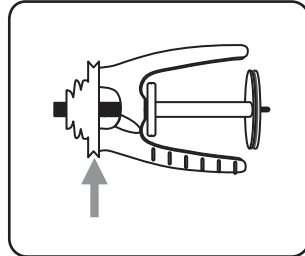

Check!

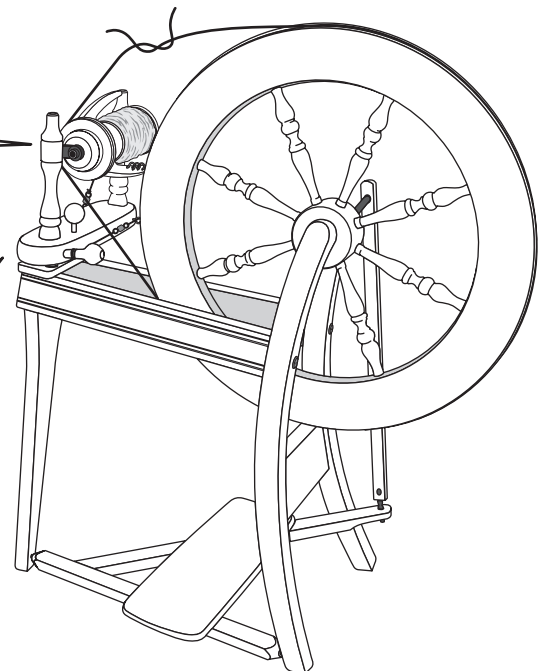
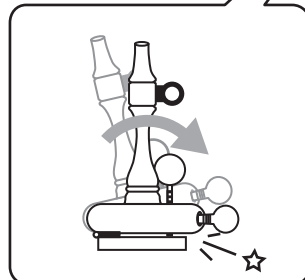

Single drive ratios:

The ratio with the drive belt around the large flyer pulley is approx. 6.5:1. To spin a finer yarn while treadling at the same speed, move the drive belt onto the middle flyer pulley and retension it. This ratio is approx. 12.5:1.

To spin a very fine yarn, move the drive belt onto the small flyer pulley and retension it. This ratio is approx. 17.5:1.

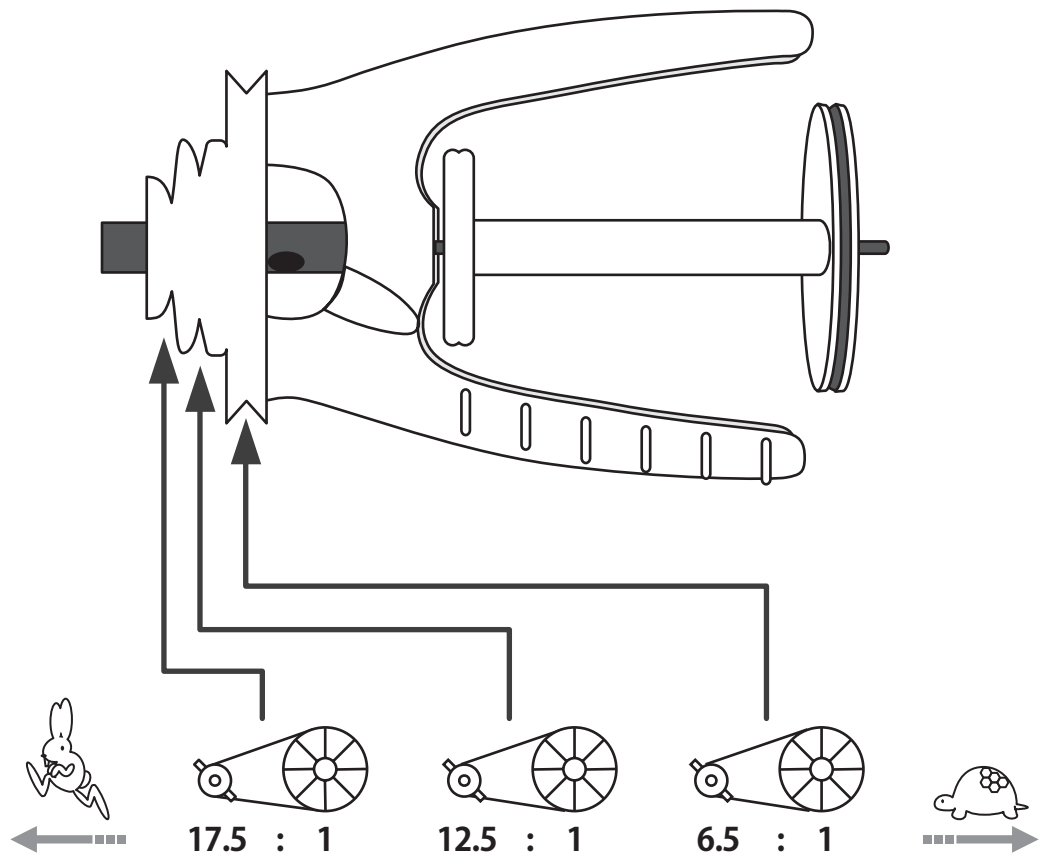

Refer to the Learn To Spin Booklet for more spinning hints.

Happy spinning.

Memo

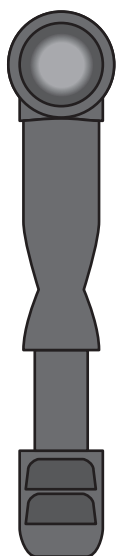

How to insert the polyurethane conrod joints into the conrod.

*This has been pre-assembled in the factory.

